

# rotork®

Keeping the World Flowing  
for Future Generations

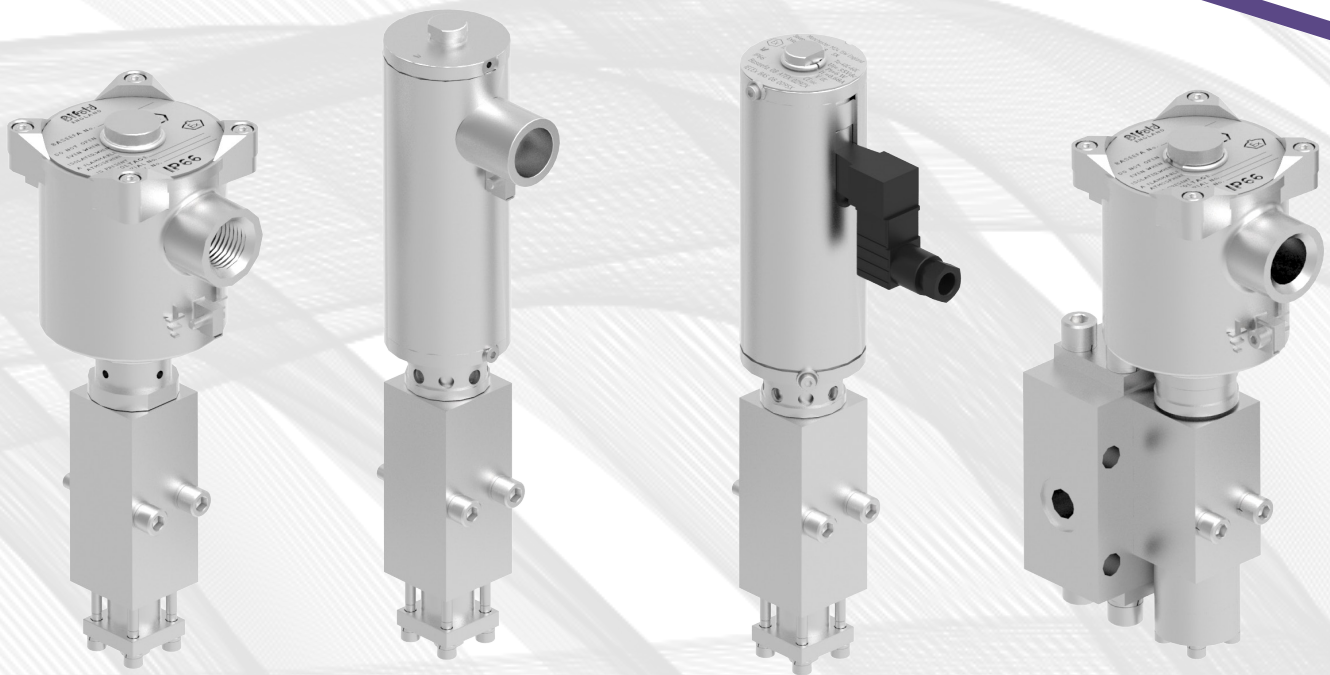

# 08

## Solenoid Valves



Hydraulic

SECTION	MEDIA	PRODUCT RANGES	PRESSURE (up to)	FLOW RATE (up to)	
07 - 10 Solenoid Valves	08	Hydraulic	Direct Acting & Indirect Acting Solenoid Valves, FP01, FP02, FP03, FP04, FP05, FP10, FP15, FP50, FP50(B), FP100, FP200, FP200(B) & SVP	1,380 bar	5.2 Cv / 200.0 l/min
	08	Hydraulic	Slide Valve Indirect Acting Solenoid Valves, SV & SVI	1,035 bar	0.708 Cv / 40.0 l/min

- Direct Acting Solenoid Valve Range 3
- Direct Acting Solenoid Valve Range 4
- Indirect Acting Solenoid Valve Range 5
- Indirect Acting Solenoid Valve Range 6
- Product Spotlight 7
  - Solenoid Valve Enclosure & Valve Body Options
- One Source..... One Solution 8
- Overview 9
- Market Sectors 10
  - Application Example
- Standard & Slimline Solenoid Valve Features & Benefits 11
  - Equipment Design & Build
  - Commissioning & Maintenance
- Standard & Slimline Solenoid Valve Features & Benefits 12
  - Safety & Environmental
- Flow Curves 13
  - FP01 Solenoid Valves Flow /  $\Delta P$  Chart
  - FP02, FP03, FP04, FP05 Solenoid Valves Flow /  $\Delta P$  Chart
- Flow Curves 14
  - SVP Solenoid Valves Flow /  $\Delta P$  Chart
  - FP15 Solenoid Valves Flow /  $\Delta P$  Chart
- Flow Curves 15
  - FP50 & FP50(B) Solenoid Valves Flow /  $\Delta P$  Chart
  - FP100, FP200 & FP200(B) Solenoid Valves Flow /  $\Delta P$  Chart
- Flow Curves 16
  - SV Solenoid Valves Flow /  $\Delta P$  Chart
  - SV Solenoid Valves Flow /  $\Delta P$  Chart
- Standard & Slimline Solenoid Valve Technical Attributes 17
  - Solenoid Valve Information
  - Materials of Construction
  - Electrical Characteristics
- Standard & Slimline Solenoid Valve Technical Attributes 18
  - Enclosure
- Direct Acting & Indirect Acting Schematics 19
- Standard & Slimline Wiring Diagrams 20
- Configurable Datasheet 21
- Product Configurator 22
- Notes 23-25

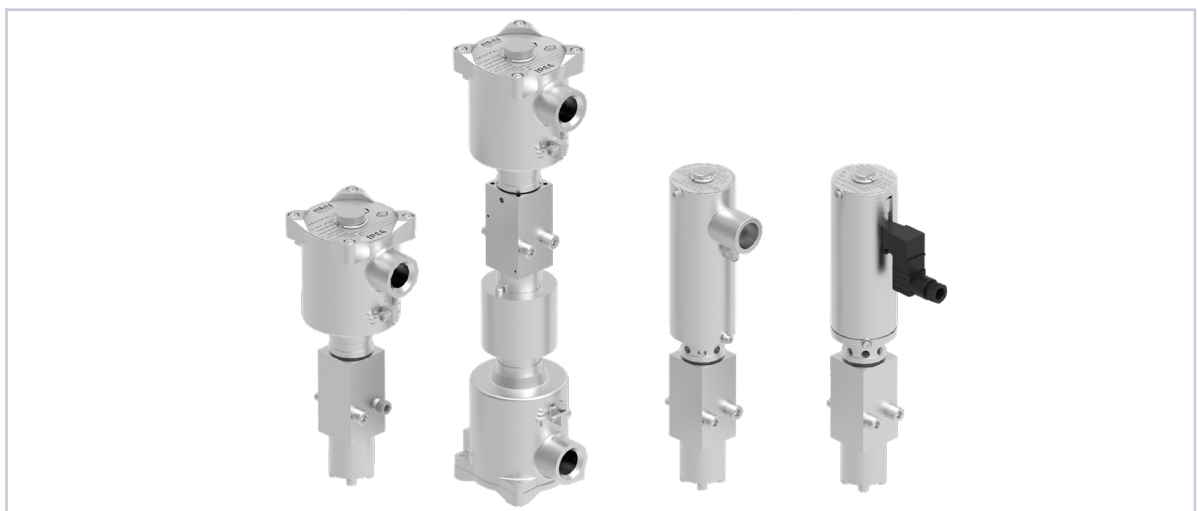
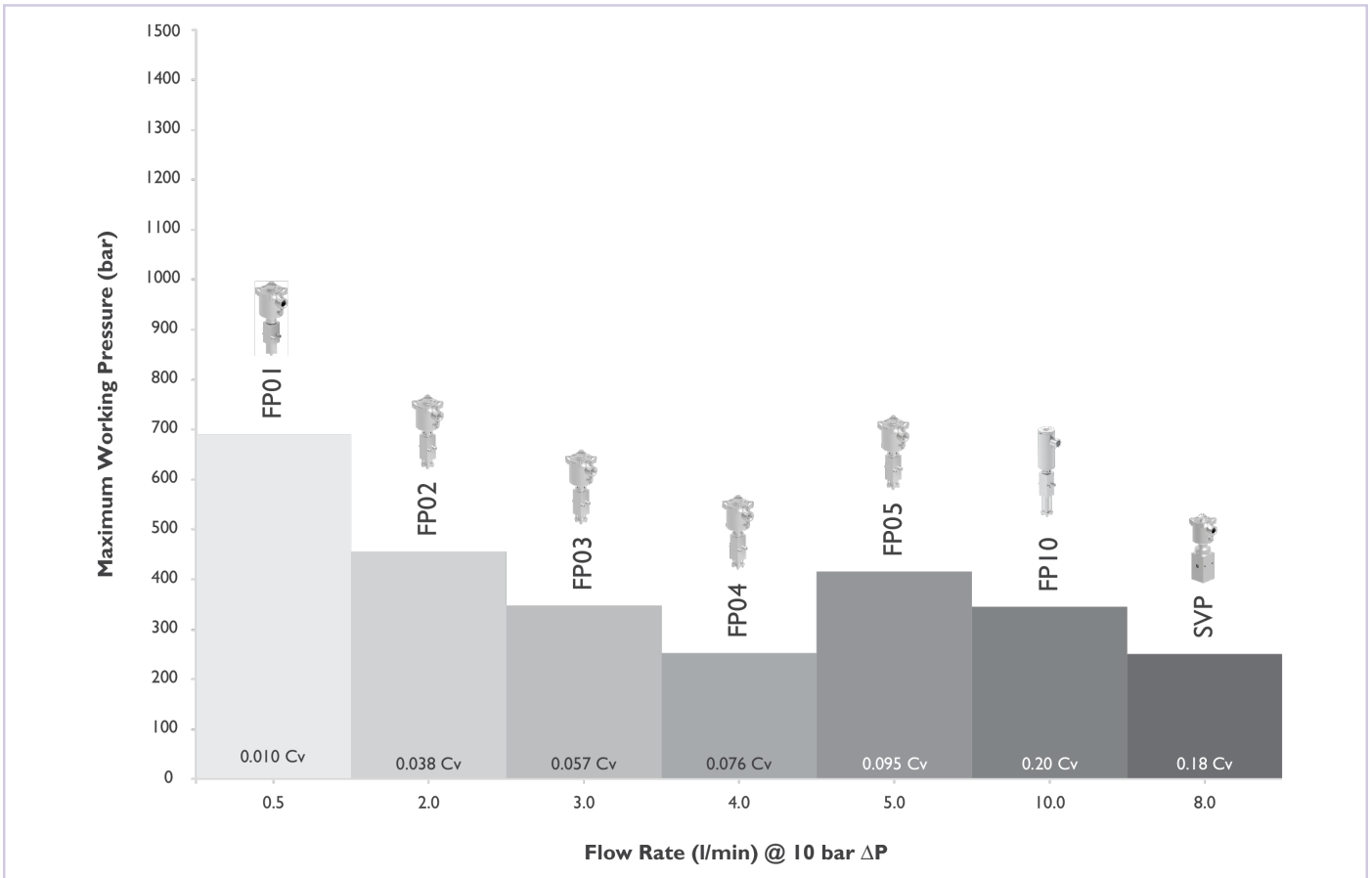
## Direct Acting Solenoid Valve Range



<b>Model Code</b>	<b>FP01</b>		
<b>Configuration</b>	2/2 & 3/2		
<b>Port Connections</b>	NPT, BSP & MP		
<b>Flow Rate</b>	From 0.010 Cv, up to 0.013 Cv / 0.5 l/min		
<b>Pressure</b>	Up to 10,000 psi / 690 bar		
<b>Power</b>	1.0W - 5.7W (Ex d)	1.8W - 3.6W (Ex emb)	155 Ohms (Ex ia) / 80 mA
<b>Mounting</b>	Sub-Base Mount  Flange Mounted  (Multiple Options Available, Please Contact Bifold for Further Information)		

# 08 Solenoid Valves Hydraulic

## Direct Acting Solenoid Valve Range

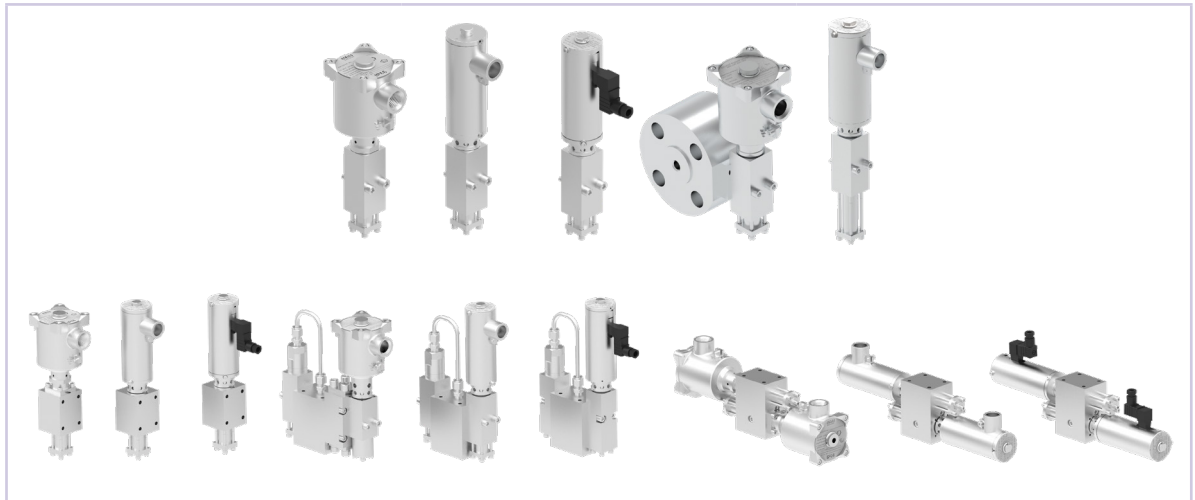

<b>Model Code</b>	<b>FP02, FP03, FP04, FP05 &amp; (FP10 Coming Soon)</b>		
<b>Configuration</b>	2/2 & 3/2		
<b>Port Connections</b>	NPT & BSP		
<b>Flow Rate</b>	From 0.04 Cv, up to 0.10 Cv / 10.0 l/min		
<b>Pressure</b>	Up to 6,527 psi / 450 bar		
<b>Power</b>	2.8 W - 10 W (Ex d)	6.8 W (Ex emb)	135 Ohms (Ex ia) / 80 mA
	4.5 W - 14 W (Ex d) (FP10 only)		
<b>Mounting</b>	Sub-Base Mount CETOP Interface (FP04 Only) Flange Mounted	} (Multiple Options Available, Please Contact Bifold for Further Information)	



<b>Model Code</b>	<b>SVP</b>
<b>Configuration</b>	2/2 & 3/2
<b>Port Connections</b>	NPT & BSP
<b>Flow Rate</b>	From 0.15 Cv, up to 0.18 Cv / 8.0 l/min
<b>Pressure</b>	3,625 psi / 250 bar
<b>Power</b>	6.5 W (Ex d)
<b>Mounting</b>	Body Ported Sub-Base Mount } (Multiple Options Available, Please Contact Bifold for Further Information)

## Indirect Acting Solenoid Valve Range

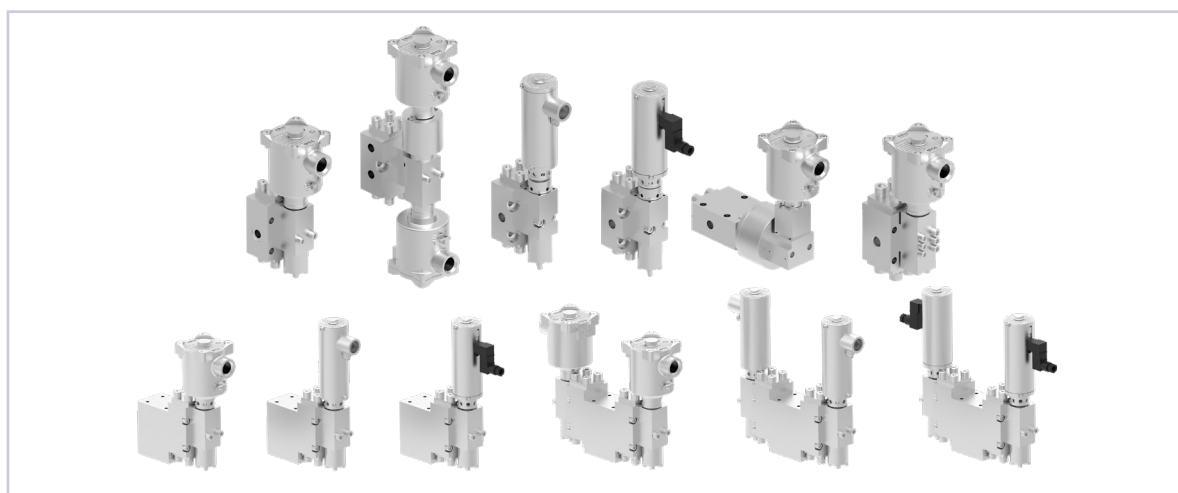
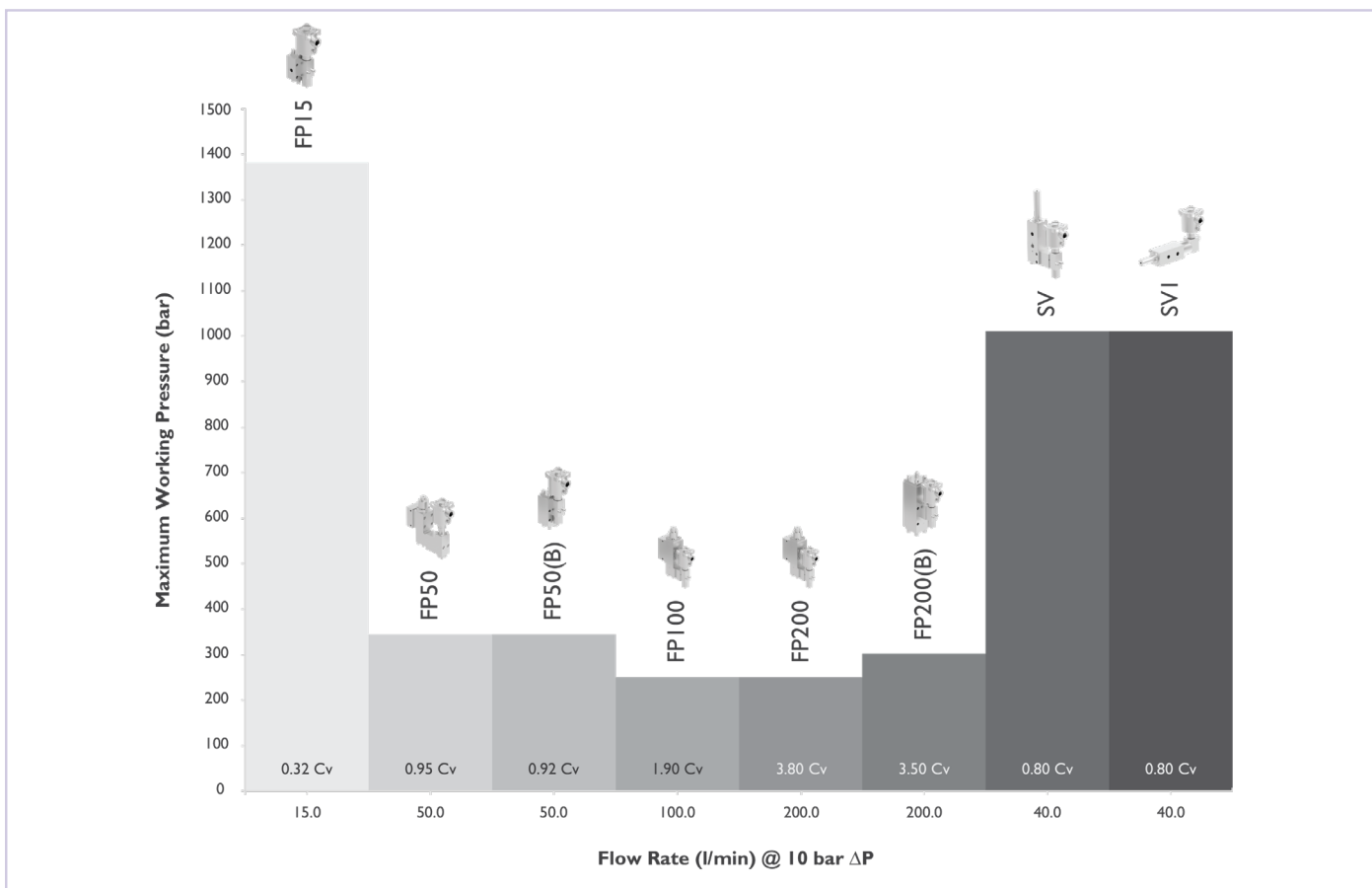

<b>Model Code</b>	FP15		
<b>Configuration</b>	2/2, 3/2, 4/2, 4/3 & 4/3/BC		
<b>Port Connections</b>	NPT, BSP & MP		
<b>Flow Rate</b>	From 0.09 Cv, up to 0.71 Cv / 15.0 l/min		
<b>Pressure</b>	Up to 20,000 psi / 1380 bar		
<b>Power</b>	1.0 W - 6.5 W (Ex d)	1.8 W - 3.6 W (Ex emb)	155 - 370 Ohms (Ex ia) / 80 - 32 mA
<b>Mounting</b>	Body Ported Sub-Base Mount CETOP Interface		
	(Multiple Options Available, Please Contact Bifold for Further Information)		

# 08 Solenoid Valves Hydraulic

## Indirect Acting Solenoid Valve Range

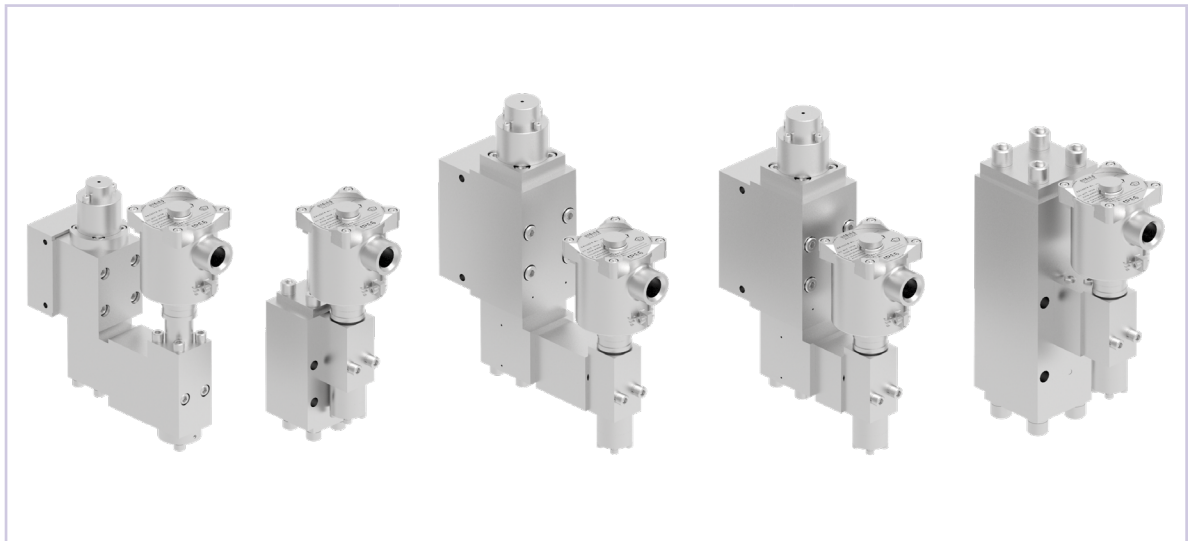

<b>Model Code</b>	<b>FP50, FP50(B), FP100, FP200 &amp; FP200(B)</b>		
<b>Configuration</b>	2/2 & 3/2		
<b>Port Connections</b>	NPT & BSP		
<b>Flow Rate</b>	From 1.0 Cv, up to 5.2 Cv / 200.0 l/min		
<b>Pressure</b>	Up to 5,000 psi / 345 bar		
<b>Power</b>	1.0 W - 6.5 W (Ex d)	1.8 W - 3.6 W (Ex emb)	155 - 370 Ohms (Ex ia) / 80 - 32 mA
<b>Mounting</b>	Body Ported <input type="checkbox"/> Sub-Base Mount <input type="checkbox"/> (Multiple Options Available, Please Contact Bifold for Further Information)		

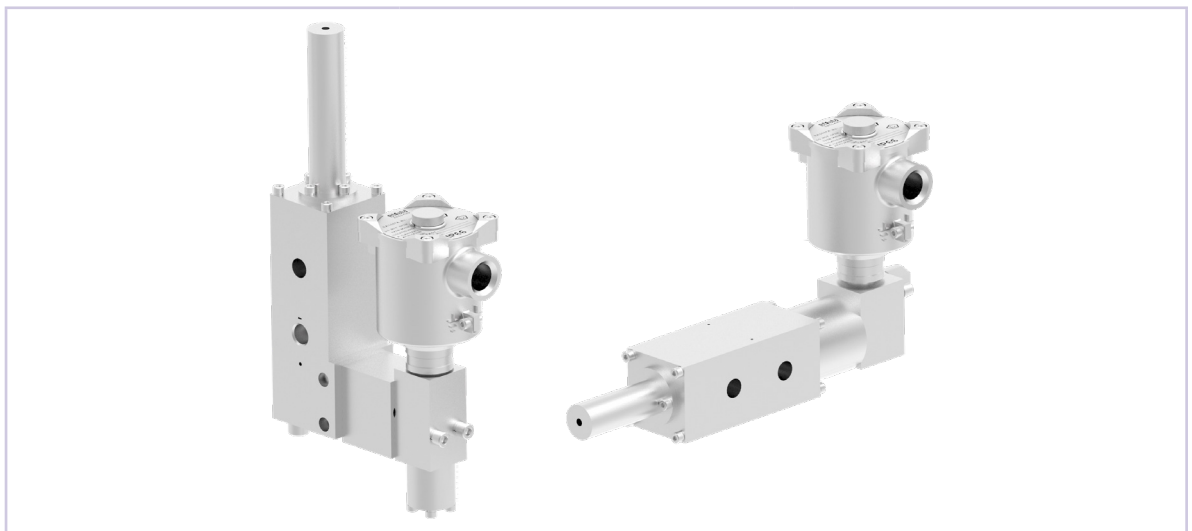

<b>Model Code</b>	<b>SV &amp; SVI</b>		
<b>Configuration</b>	2/2, 3/2 & 5/2		
<b>Port Connections</b>	NPT, BSP & MP		
<b>Flow Rate</b>	From 0.3 Cv, up to 0.708 Cv / 40.0 l/min		
<b>Pressure</b>	15,000 psi / 1,035 bar		
<b>Power</b>	1.0 W - 6.5 W (Ex d)	1.8 W - 3.6 W (Ex emb)	155 Ohms (Ex ia) (SV only) / 80 mA 370 Ohms (Ex ia) (SVI only) / 32 mA
<b>Mounting</b>	Body Ported <input type="checkbox"/> Sub-Base Mount <input type="checkbox"/> (Multiple Options Available, Please Contact Bifold for Further Information)		

## Product Spotlight



### Chemical Injection - (FP01, FP02, FP03, FP04 & FP05)

- Flange mounting for a pipeline installation
- Designed for chemical injection systems
- Typical flange connections API 6A and ASME B16.5
- Exotic materials available for harsh chemicals where required

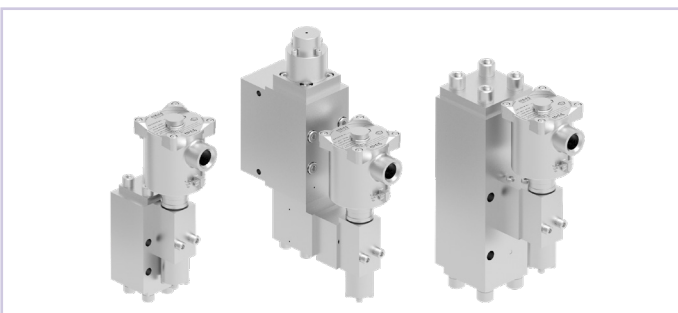

### Highest Flow - (FP50(B) & FP200(B))

- Low power consumption
- High flow capabilities
- Block before bleed (two stage valves)

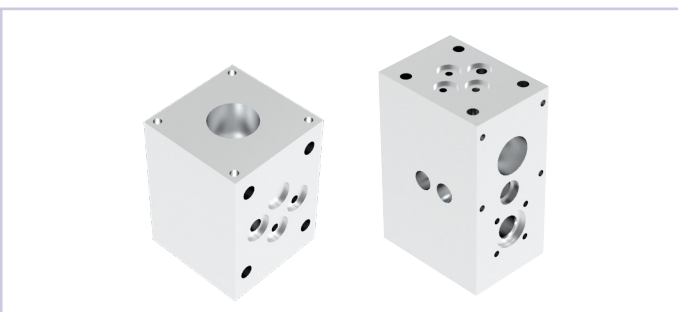

### CETOP 03 - (FP04 & FP15)

- CETOP 03 interface
- Retrofittable to existing customer interfaces
- Block before bleed (two stage valves)
- ISO 4401-03 standard interface

## Solenoid Valve Enclosure & Valve Body Options



7x	74AT4, 77 & 78 Series	316L Stainless Steel Enclosure and Valve Body
2x	24, 27 & 28 Series	Aluminium Enclosure and 316L Stainless Steel Valve Body
5x	57 & 58 Series	Carbon Steel Enclosure with 316L Stainless Steel Over Sleeve and 316L Stainless Steel Valve Body
3x & 6x	38, 67 & 68 Series	Carbon Steel Plated Enclosure and 316L Stainless Steel Valve Body



1	Standard	24 & 74AT4 Series (Ex emb), 27 & 77 Series (Ex d), 77 Series (Explosion Proof) & 28 & 78 Series (Ex ia)
2	Slimline	57 & 67 Series (Ex d)
3		38 & 68 Series (Ex ia)

# 08 Solenoid Valves Hydraulic

One Source..... One Solution

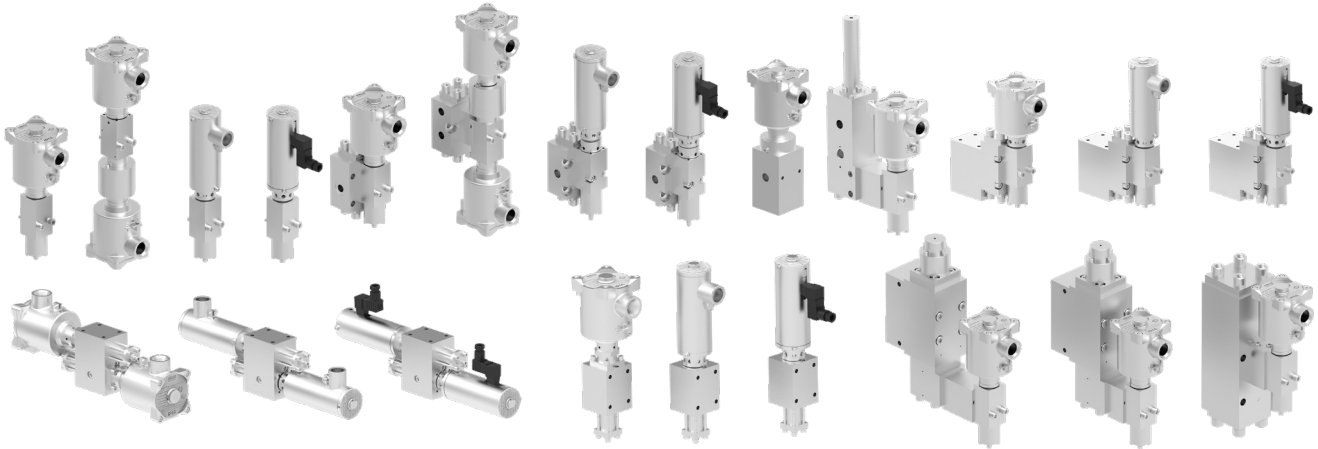

## SETTING THE STANDARD:



**100%**

Outperforms all other solenoid valves in the industry.



**1.0W**

Ultra low power consumption, 1.0W continuous power ideal for solar applications.



**No 1**

For global wellhead, process, choke, valve actuation, deluge and fire damper markets.



**1/8" 3/4"**  
UPTO

Wide Range of operating media covered - 1/8" to 3/4" ports, 2/2, 3/2, 4/2, 4/3 and 5/2, 2 out of 3 voting and over 3.8 x 10<sup>7</sup> permutations - every application covered.



**£\$€**

Low Cost Solution - Increase safety with no downtime and no leakage, without compromising on cost.



The only solenoid valve manufacturer with working pressures from 0 to 20,000 psi / 0 to 1,380 bar.



CETOP 03 - Designed for subplate mounting with an interface in accordance with ISO 4401-03 standard.



Capability to offer an expedited delivery service.



Highest qualified safety factors in the industry - Worldwide Ex Hazardous Area solenoid approvals: Ex emb, Ex d, Ex ia, Explosion Proof & Safe Area use, SIL 3 third party certified options available.



World leading supplier of control valves for low and high temperature applications.

## Overview

### Hydraulic Direct Acting & Indirect Acting Solenoid Valves, FP01, FP02, FP03, FP04, FP05, FP10, FP15, FP50, FP50(B), FP100, FP200, FP200(B) & SVP



Manufactured from 316L stainless steel as standard, with aluminium and carbon steel options available, our range of hydraulic solenoid valves are ideally suited for hazardous (classified) locations and corrosive atmospheres. Ultra low power consumption, under 1.0W continuous power ideal for solar applications up to 10.0W.

- Compatible with fluids at NAS1638 Class 9 and ISO 4406 18/15
- High flow - up to 5.2 Cv / 200.0 l/min
- Working pressure up to 20,000 psi / 1,380 bar
- Block before bleed (two stage valves) for system design optimisation
- Ceramic ball and exotic material seat for chemical and high cycle life applications available
- CETOP 03 option
- Medium pressure connections available (selected models)
- Gaseous Service option (please see the Gaseous Solenoid Valve Catalogue 09)

## Overview

### Hydraulic Slide Valve Indirect Acting Solenoid Valves, SV & SVI

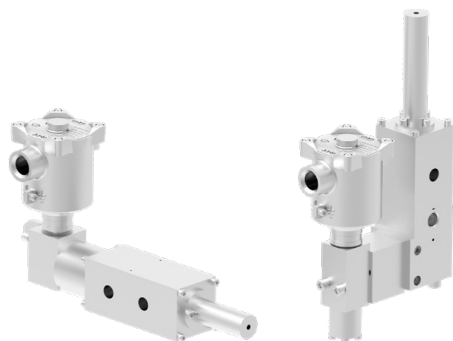

Manufactured from 316L stainless steel as standard, our range of hydraulic solenoid valves are ideally suited for hazardous (classified) locations and corrosive atmospheres. Low power consumption, power from 1.0W up to 3.6W.

- Compatible with fluids at NAS1638 Class 12 and ISO 4406 18/15
- High flow - up to 0.708 Cv / 40.0 l/min
- Working pressure up to 15,000 psi / 1,035 bar
- Block before bleed (two stage valves) for ease of system design
- Leaktight crossover function

# 08 Solenoid Valves Hydraulic

## Market Sectors

- Wellhead Controls & Associated Field Instrumentation
- Umbilical Reelers
- Chemical Injection
- Shale Gas
- Process Choke Valve Actuation
- Ship / Vessel Ballast & Cargo Handling Valve Controls
- HPU (Hydraulic Power Unit)
- Process Skids & Modules
- Process Valve Actuator & Pipeline ESD (Emergency Shut Down) Valve Actuator Controls
- HIPPS (High Integrity Pressure Protection Systems)

Note: Not all of the hydraulic solenoid valve ranges are available for some of the market sectors listed above, please see the full market sector list for details.

## Application Example

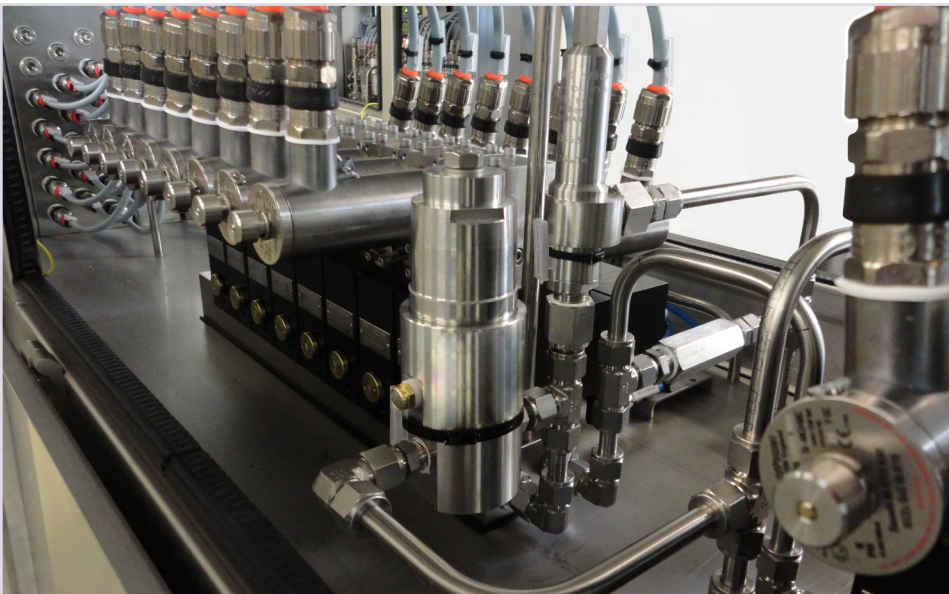
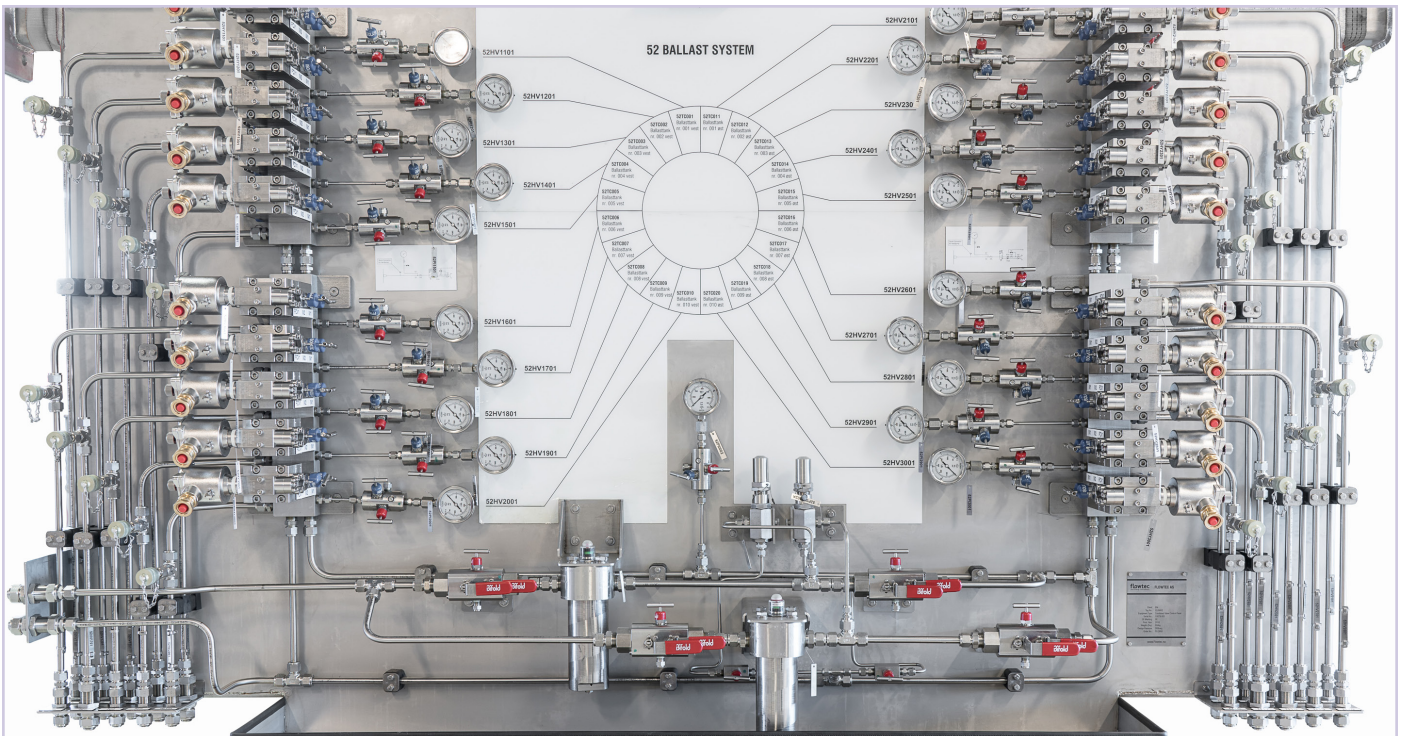

## Standard & Slimline Solenoid Valve Features & Benefits

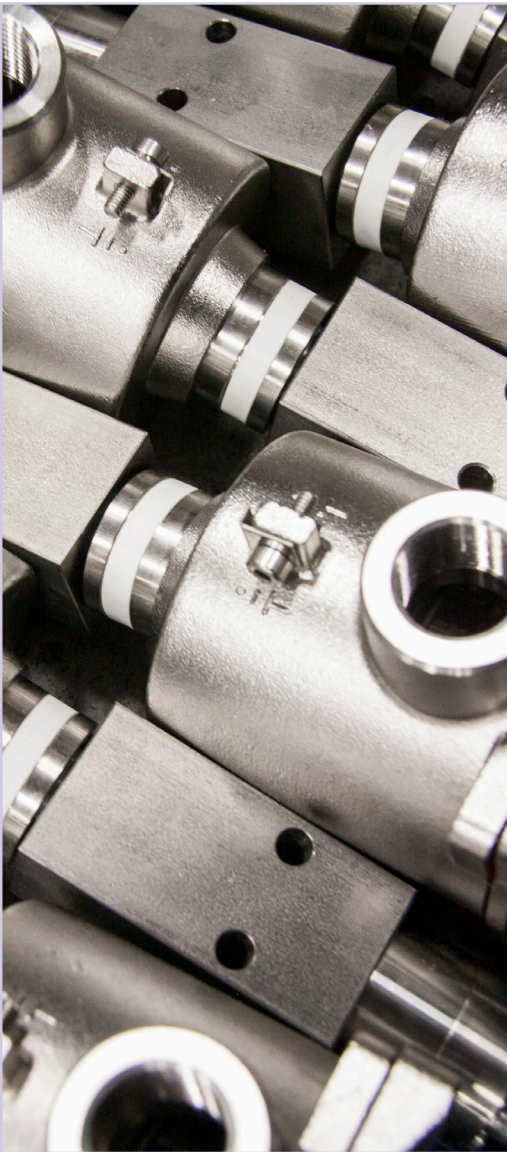

### Equipment Design & Build

- Standard and slimline solenoid operator is free to rotate 360° allowing for an easy cable layout and ease of connection wiring. Solenoid operator internals rotate with the enclosure and prevent cables being pulled out of the terminal block.
- Widest range of override options: auto reset, stayput manual override, manual push button override and manual reset.
- Standard solenoid valve can be mounted in any orientation to simplify installation and also due to all the components having enhanced rotational capabilities.
- Coils fully encapsulated as standard.
- Seated ball design offers extremely low leakage (reducing hydraulic accumulation requirements, smaller pump size and duty).
- Ceramic ball and exotic material seat for chemical and high cycle life applications
- All internal wetted and body materials conforming to NACE MR-01-75 (option).
- Compatible with fluids at NAS1638 Class 9 and ISO 4406 18/15 (FP01, FP02, FP03, FP04, FP05, FP10, FP15, FP50, FP50(B), FP100, FP200, FP200(B) and SVP) and Compatible with fluids at NAS1638 Class 12 and ISO 4406 18/15 (SV & SVI).
- Simple installation and operation - single enclosure with integral override options.
- Low / high temperature options.
- Ultra low power consumption, 1.0 W continuous holding power, ideal for solar applications.
- Compatible within our valve assembly modular systems.

### Commissioning & Maintenance

- Tropicalised solenoid operator design - 316L stainless steel as standard with aluminium and carbon steel options also available. Further mild steel valve mount options can be selected; stainless steel or Remko B magnetic parts (dependant upon solenoid Ex series). Fully encapsulated coil.
- Worldwide technical and field support.
- Spacious solenoid enclosure for ease of wiring.
- No special high temperature cable requirements.
- No time penalty for heat dissipation before removing solenoid enclosure cover.
- Simple maintenance - Removable transient suppression diode on Ex d DC solenoid valve assemblies as standard and removable solenoid coil without removing valve from the tubing.
- Compact design and space envelope.



## Standard & Slimline Solenoid Valve Features & Benefits

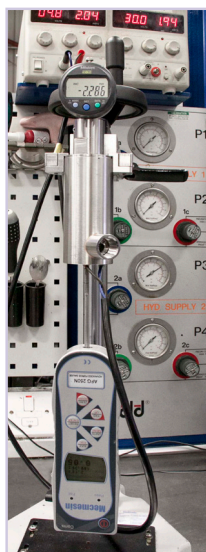

### Safety & Environmental

- Worldwide Ex hazardous area solenoid approvals: Ex emb, Ex d, Ex ia, explosion proof & safe area use.
- SIL 3 capability: The product has met manufacturer design process requirements of Safety Integrity Level (SIL) 3 in accordance with IEC 61508. (For the FP01, FP02, FP03, FP04, FP05, FP15, FP50(B) & FP200(B)).
- Consistent high safety factors.
- The 77 series Ex d solenoid enclosure has been designed with 'spigot' and 'threaded' type flame path joints. The minimum spacing requirements for obstruction of 'flange' joints - regarding the installation of the solenoid enclosure and its proximity with other objects is not applicable (in accordance with IEC/BS EN 60079-14 Explosive atmospheres: Electrical installations design, selection and erection).
- Force balanced valve design with high safety factors to de-energise at all pressures in Normally Open and Normally Closed configurations.
- 100% computerised diagnostic testing to ensure each solenoid valve is proven along with confirmed safety factors.
- Bifold has state of the art product qualification and production equipment including flow (Cv), environment (-60°C to +180°C), function and leakage testing and data logging.
- The standard solenoid operator is a flat plate armature type which ensures the valve will operate in all conditions. Other solenoid valve types using core tube design solenoid operators risk corrosion and seizure of the armature within the core tube.
- High tolerance to field misuse.
- Products are manufactured, inspected, assembled and tested in our state of the art production facilities.
- Large clearances, metal back up to seals and no knife edge sealing to prevent long term valve sticking.

## Flow Curves

FP01 Solenoid Valves Flow /  $\Delta P$  Chart

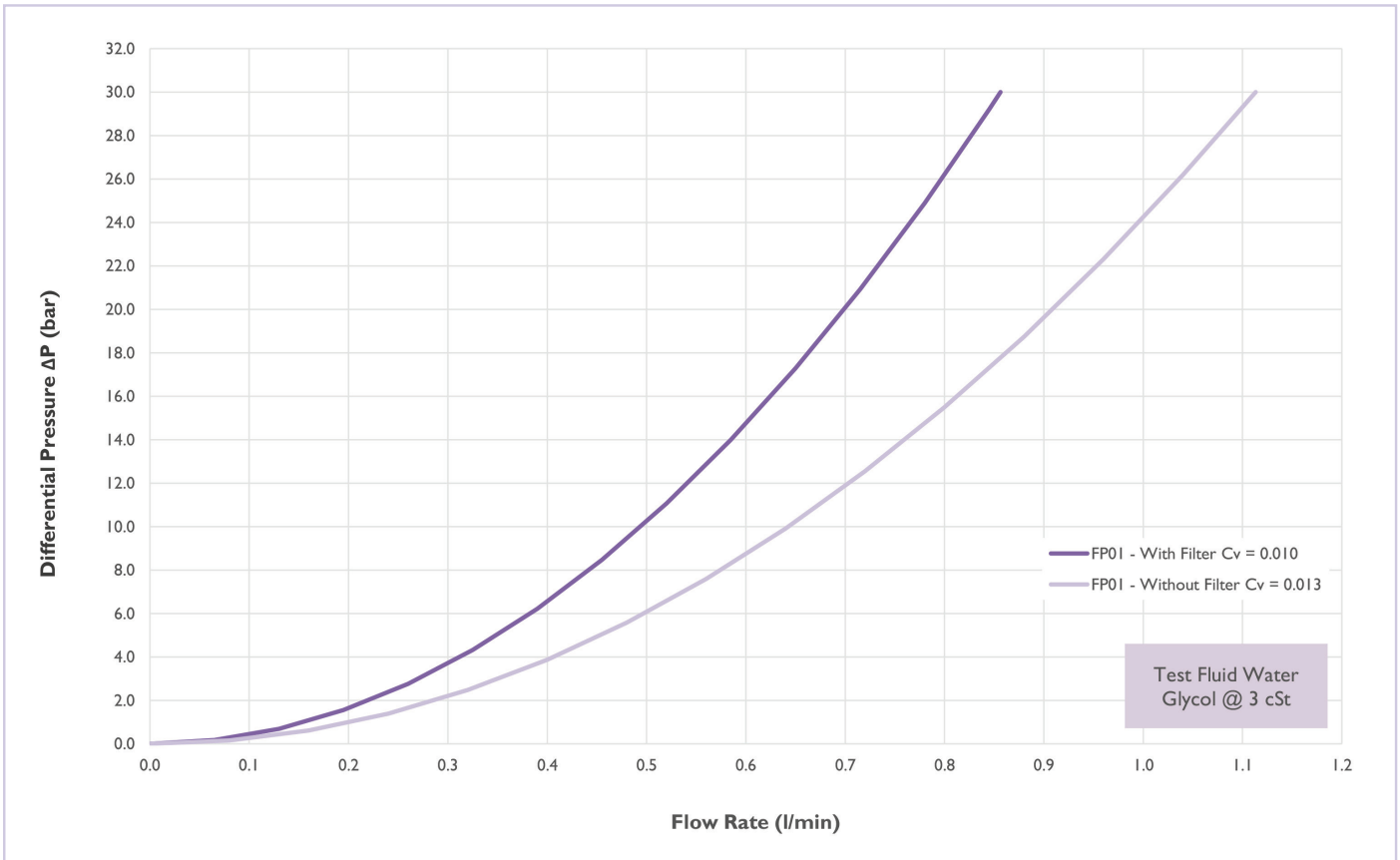

FP02, FP03, FP04, FP05 Solenoid Valves Flow /  $\Delta P$  Chart

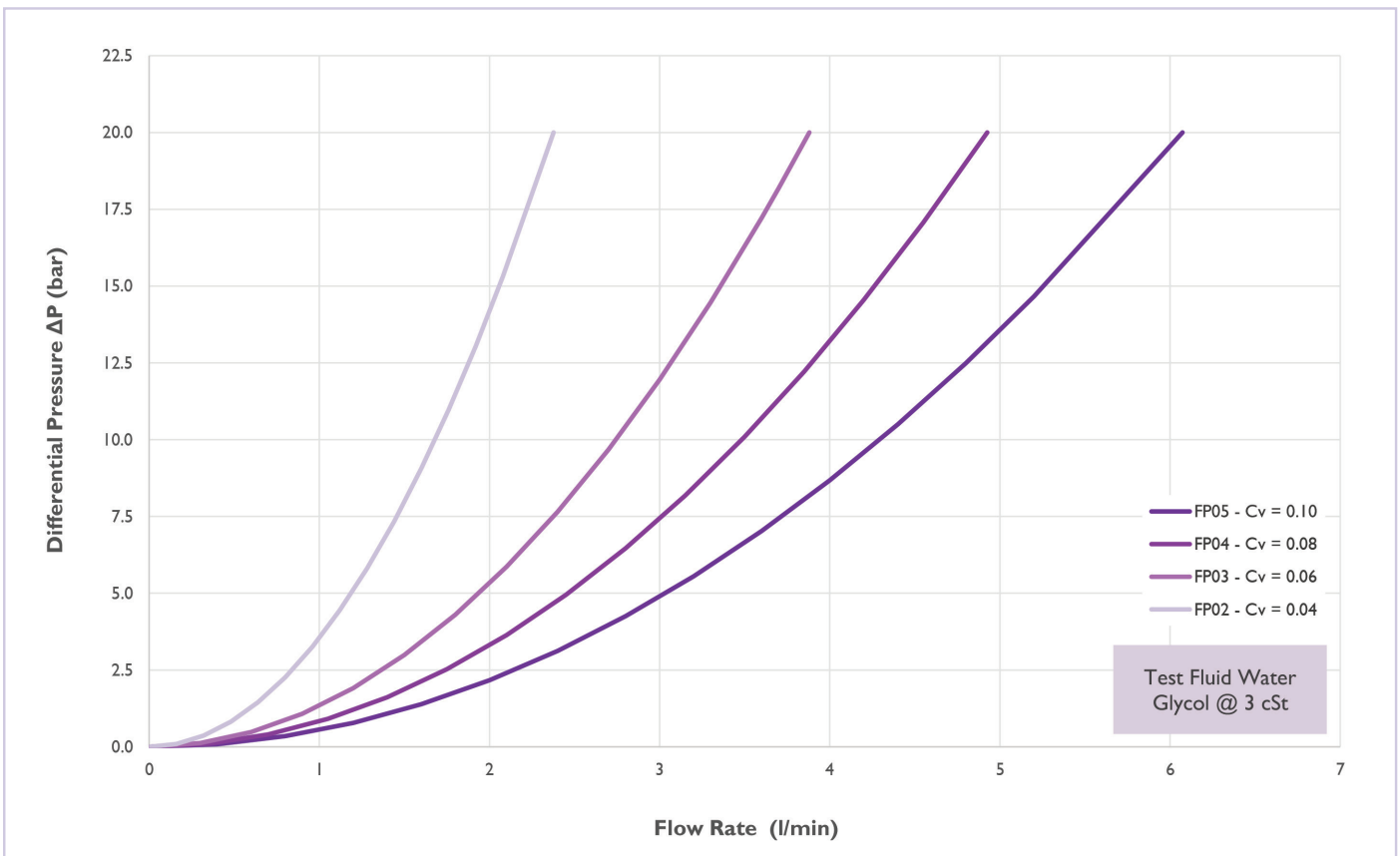

# 08 Solenoid Valves Hydraulic

## Flow Curves

SVP Solenoid Valves Flow /  $\Delta P$  Chart

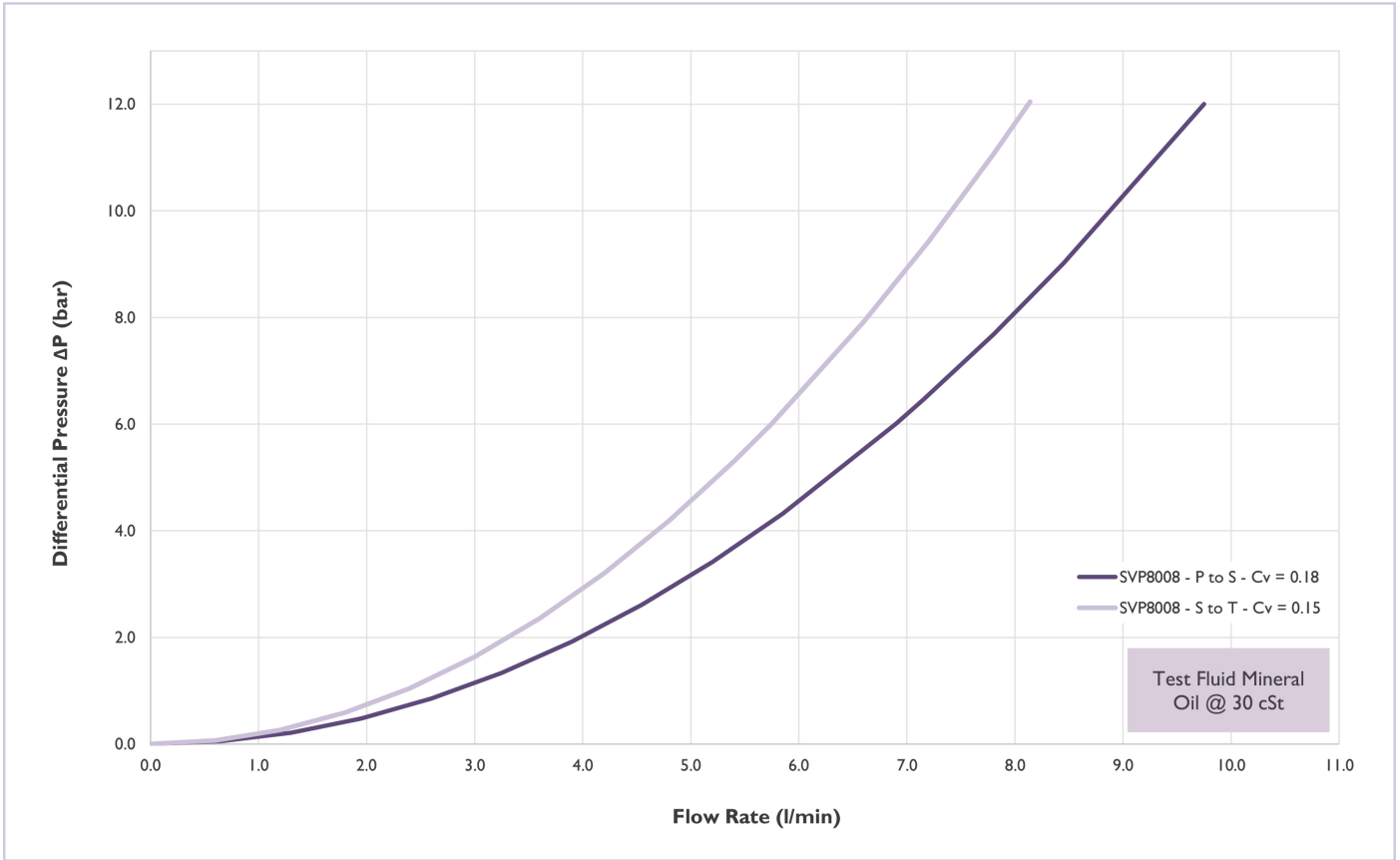

FPI5 Solenoid Valves Flow /  $\Delta P$  Chart

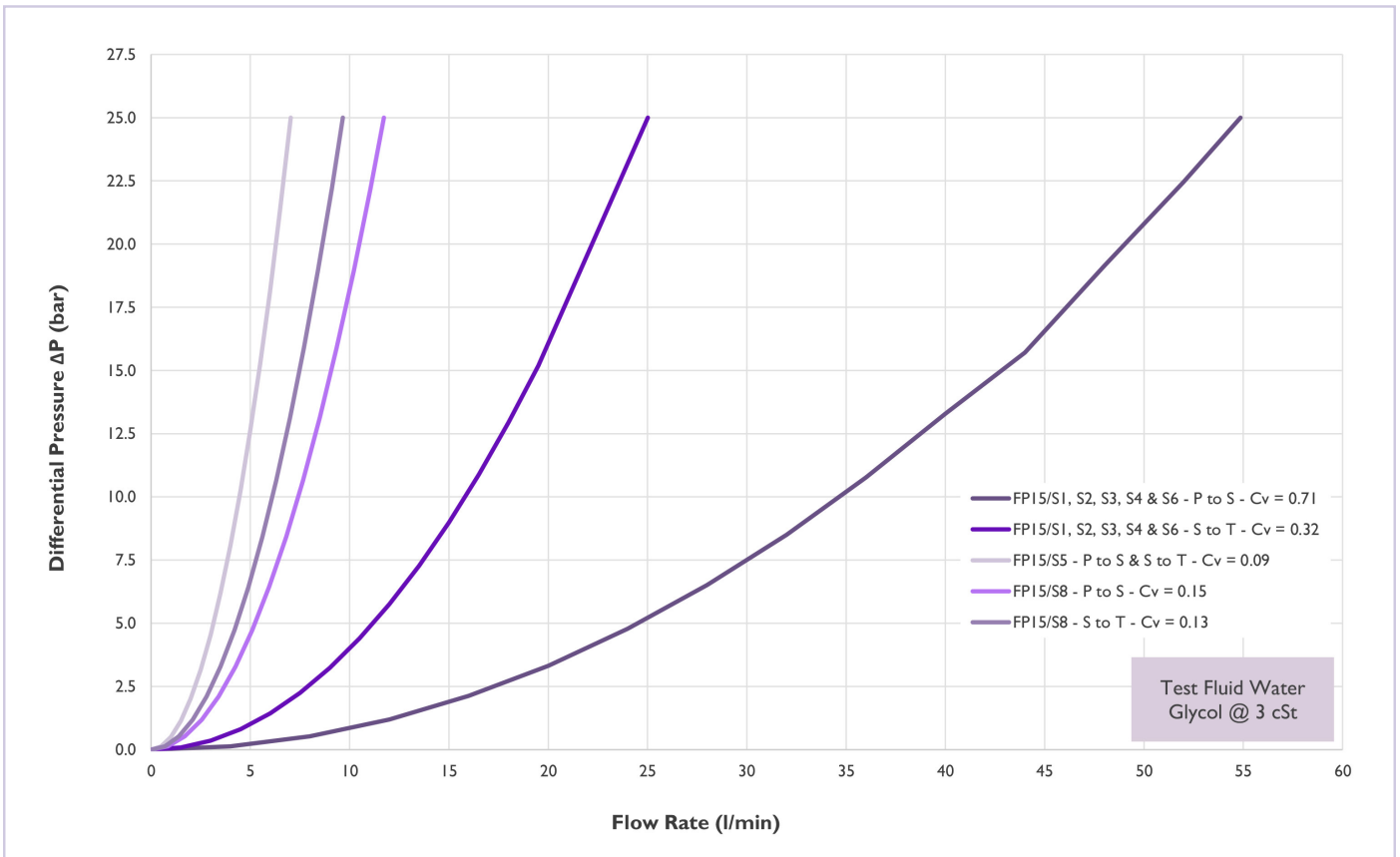

## Flow Curves

### FP50 & FP50(B) Solenoid Valves Flow / $\Delta P$ Chart

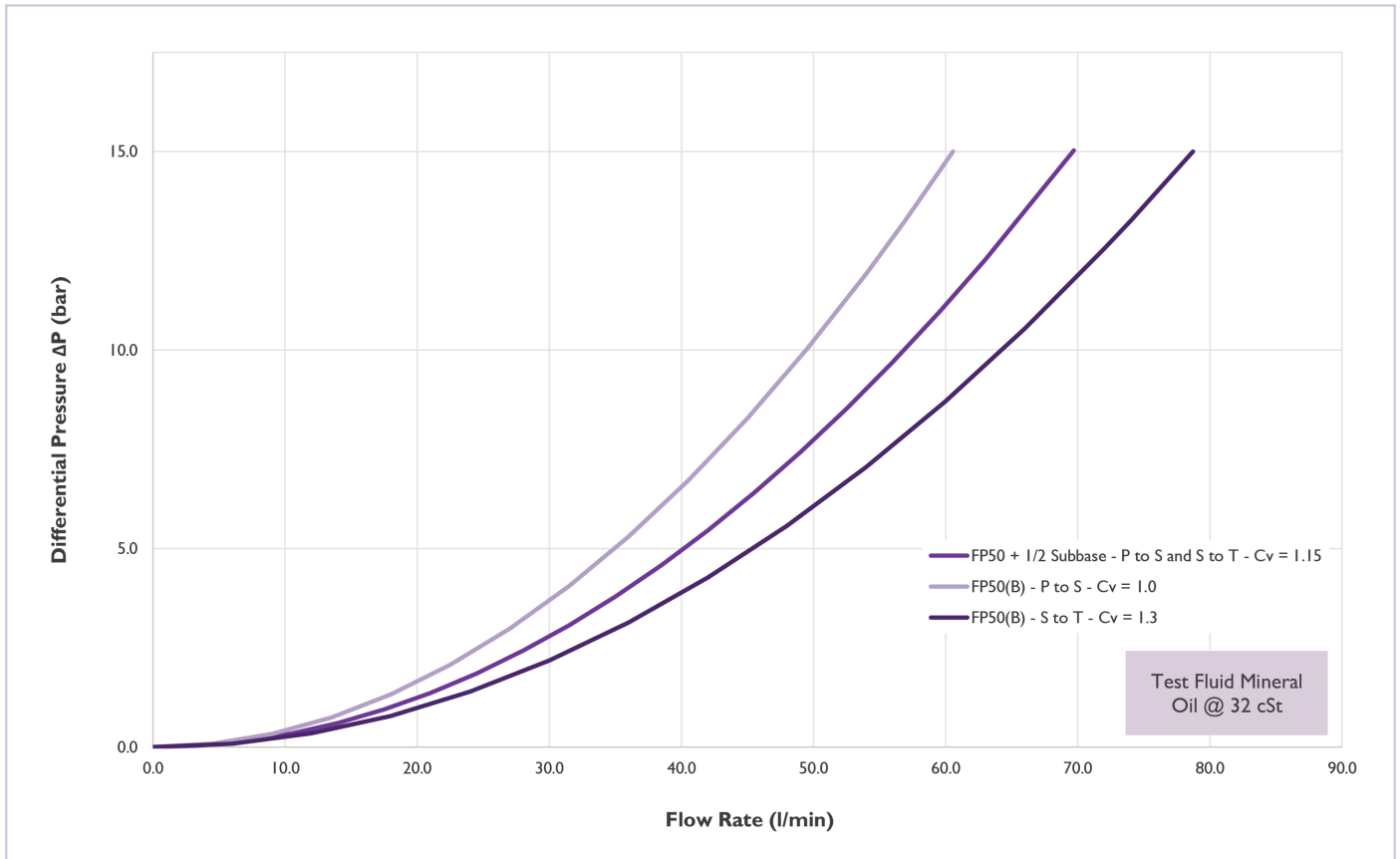

### FP100, FP200 & FP200(B) Solenoid Valves Flow / $\Delta P$ Chart

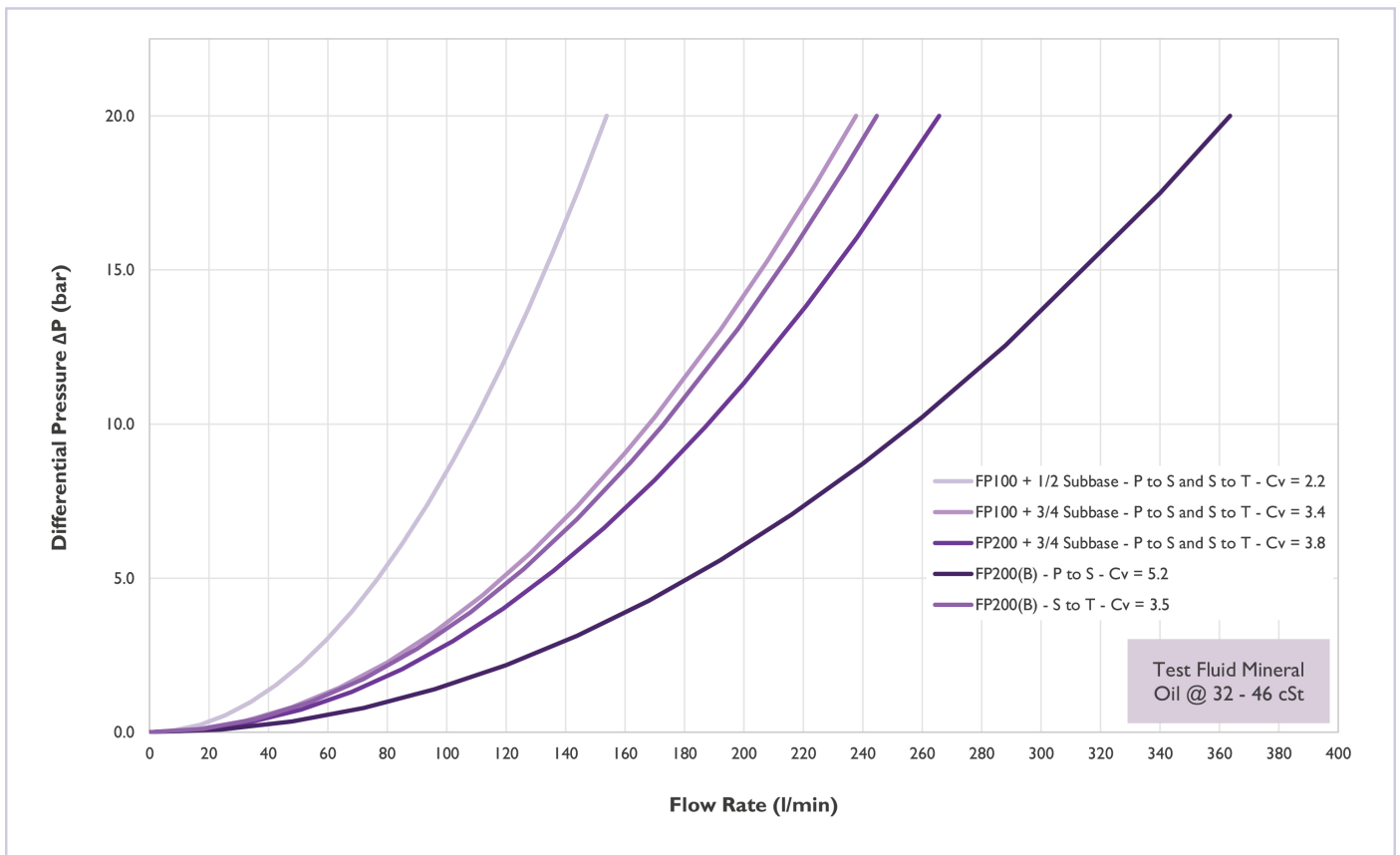

# 08 Solenoid Valves Hydraulic

## Flow Curves

SV & SVI Solenoid Valves Flow /  $\Delta P$  Chart

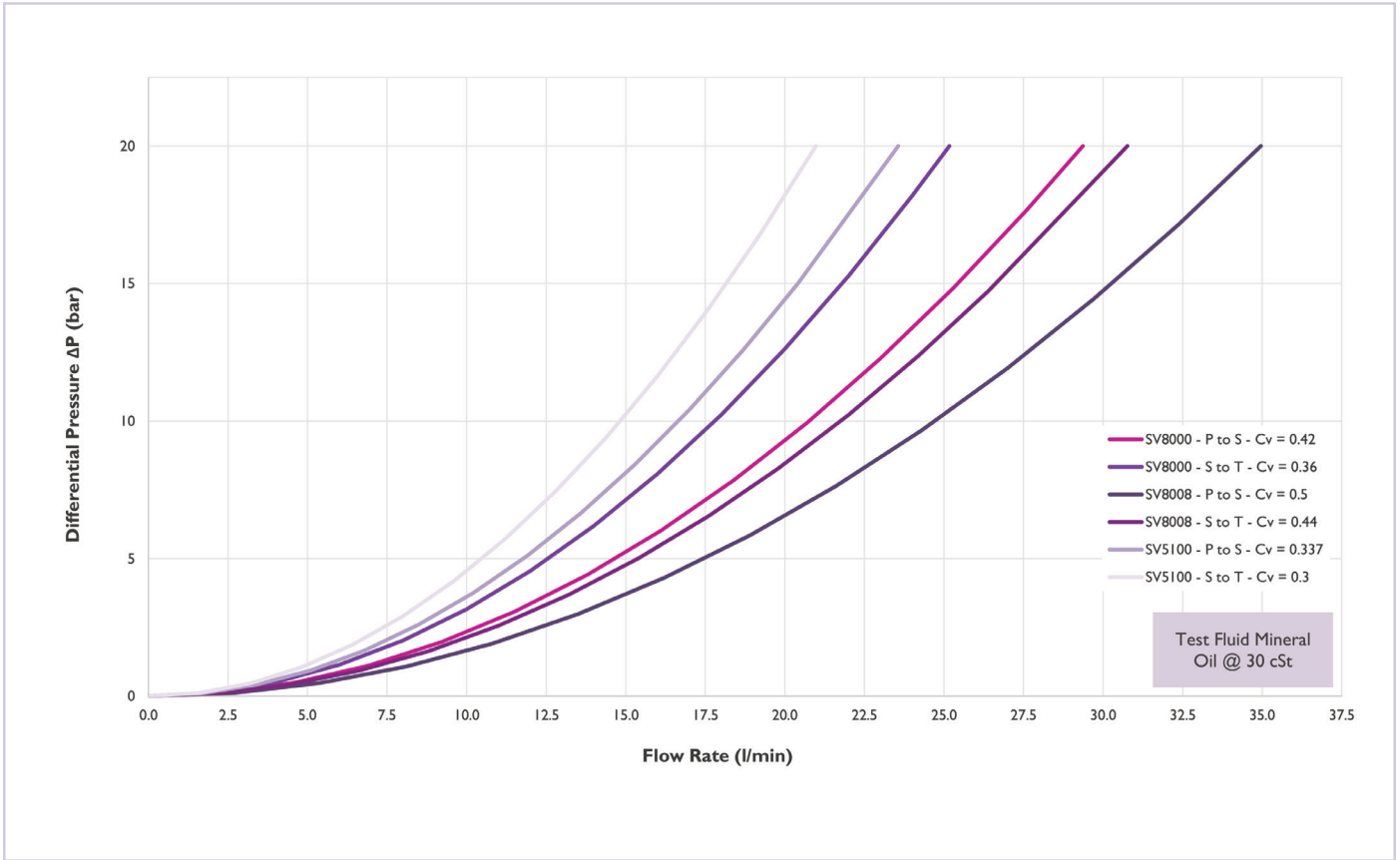

SV & SVI Solenoid Valves Flow /  $\Delta P$  Chart

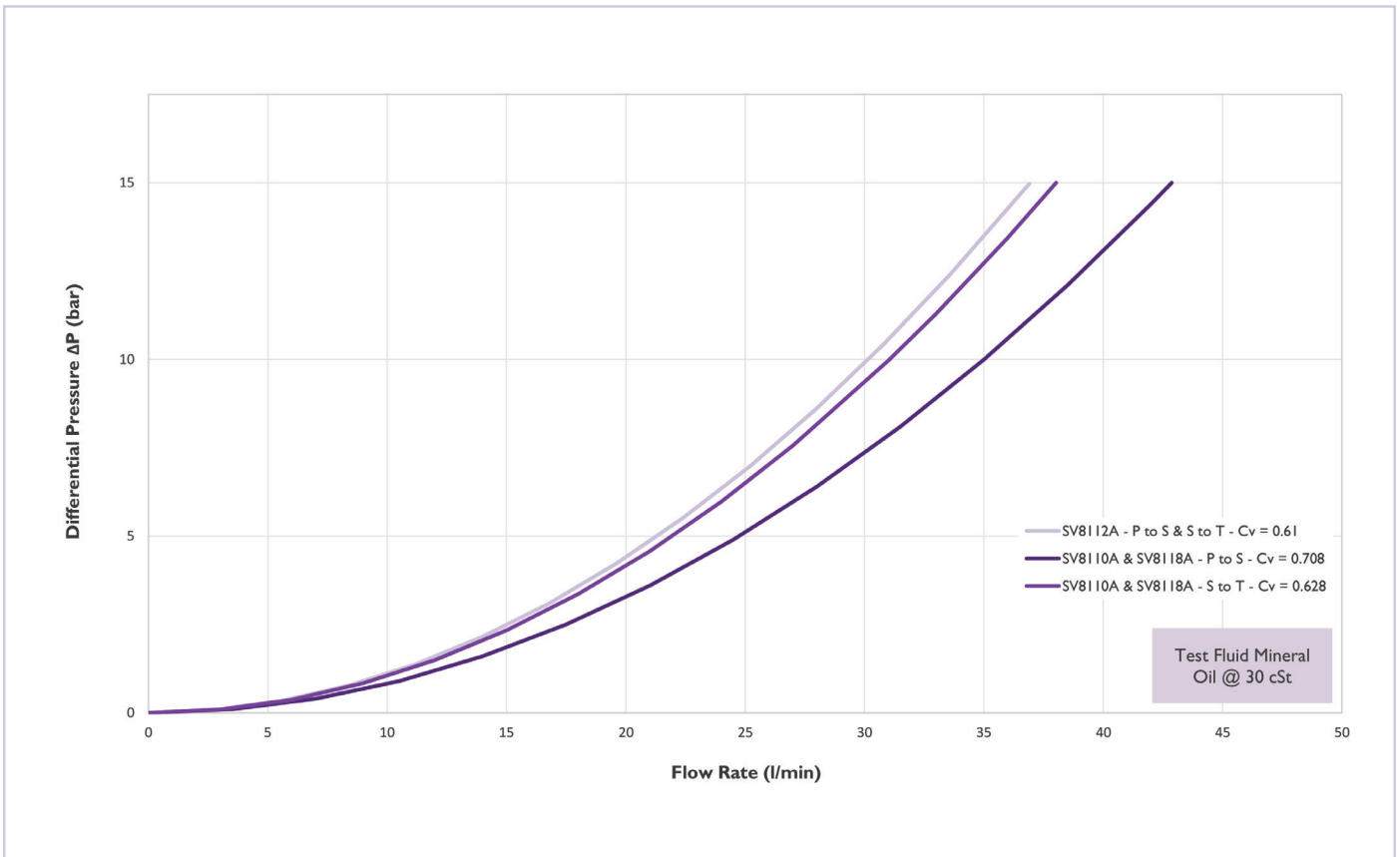

## Standard & Slimline Solenoid Valve Technical Attributes

Solenoid Valve Information											
Model Codes	FP01, FP02, FP03, FP04, FP05, FP10, FP15, FP50, FP50(B), FP100, FP200, FP200(B), SVP, SV & SVI										
Connections	¼" up to 1" (NPT, BSP, MP & via Sub-Base Mount)										
Cv	0.010 up to 5.2										
Working Pressure	0 - 20,000 psi / 0 - 1,380 bar (Maximum)										
Enclosure Type	Standard						Slimline				
Enclosure Series	24	74AT4	27	77	28	78	57	67	38	58	68
Solenoid Classification	Ex emb IIC Gb T3 / T4		Ex d IIC Gb T4 / T5 / T6		Ex ia IIC Gb T4 / T6		Ex ia IIC Ga T4 / T6		Ex d IIB Gb T80°C - T130°C		Ex ia IIC Ga T6
Ingress Protection	IP66, IP67 and 4X		IP66, IP67 and 4X		IP66, IP67 and 4X		IP66, IP67 and 4X		IP66		IP66
Maximum Leakage Rate	FP01, FP02, FP03, FP04, FP05, FP10 & SVP						<4ml/hr (0.06cc/min) Mineral Oil <8ml/hr (0.13cc/min) Water Gylcol				
	FP15, FP50(B), SV & SVI						<8ml/hr (0.13cc/min) Mineral Oil <16ml/hr (0.26cc/min) Water Gylcol				
	FP50						<10ml/hr (0.16cc/min) Mineral Oil <20ml/hr (0.33cc/min) Water Gylcol				
	FP100, FP200 & FP200(B)						<12ml/hr (0.2cc/min) Mineral Oil <24ml/hr (0.4cc/min) Water Gylcol				
Materials of Construction											
Enclosure & Valve Body	316L stainless steel as standard with aluminium and carbon steel options also available										
Internal Components	316L stainless steel, AISI 440C, CA104 aluminium bronze, Inconel 718 and ceramic										
Springs	302S26 & 316S42 stainless steel as standard										
Fasteners	Metric A4 18/10 grade stainless steel; equivalent to 316L grade stainless steel										
O-ring Material	NBR - Nitrile (Standard) HNBR - Nitrile (Low Temperature) FKM - Fluoroelastomer FVMQ - Fluorosilicone FFKM - Perfluoroelastomer		<b>Media Temperature Range</b> Up to -20°C to +130°C (Dependant on seal type. Alternative elastomer's available for extreme conditions and to suit media)								
			<b>Ambient Temperature Range</b> Up to -20°C to +90°C (Dependant on Solenoid Classification) Up to -46°C (Selected Arctic Service Models)								
Operating Media	Mineral oils, water glycol mixtures, sea water (filtered) and some chemicals										
Conformity	All internal wetted and body materials conforming to NACE MR-01-75 (option) SIL 3 capability: The product has met manufacturer design process requirements of Safety Integrity Level (SIL) 3 in accordance with IEC 61508. (For the FP01, FP02, FP03, FP04, FP05, FP15, FP50(B) & FP200(B))										
Electrical Characteristics											
Duty cycle	100% continuously rated / energised										
Response Times	Pull in <100ms, drop out <70ms										
Solenoid Insulation	Class H										
Volts	Pull-In volts 90% up to 110% nominal						Drop-out volts, typically 10 - 20% of nominal				
Coil Voltage DC (=)	12V DC up to 240V DC										
Coil Voltage AC 50Hz and 60Hz (≈)	24V AC up to 240V AC										
Cable Entry	M20 x 1.5, ½" NPT and Din 43650 Connector (38 Series (Ex ia))										
Bifold solenoid valves must be installed, operated and maintained in accordance with the relevant Bifold installation, operating and maintenance instructions, relevant installation rules, regulations and codes of practice.											

# 08 Solenoid Valves Hydraulic

## Standard & Slimline Solenoid Valve Technical Attributes

Enclosure					
Certification	 (Please contact bifold for available certification)				
Protection Class (Ex emb) - 24 & 74AT4 Series	II 2 GD c Ex emb IIC Gb T3 Tamb -25°C to +55°C (powers up to 3.0W or below) II 2 GD c Ex emb IIC Gb T4 Tamb -25°C to +50°C (powers up to 4.0W or below) II 2 GD c Ex emb IIC Gb T3 Tamb -25°C to +45°C (powers up to 4.5W or below) II 2 GD c Ex emb IIC Gb T3 Tamb -25°C to +40°C (powers up to 6.8W or below)				
Protection Class (Ex d) - 27, 57, 67 & 77 Series	27 & 77 - II 2 GD Ex db IIC Gb T6 (Tamb -60°C to +40°C) II 2 GD Ex db IIC Gb T5 (Tamb -60°C to +55°C) II 2 GD Ex db IIC Gb T4 (Tamb -60°C to +90°C) 57 & 67 - II 2 GD Ex d IIB Ex tD A2I IP66 T80°C (Tamb -40°C to +40°C)				
Power	24 & 74AT4 (Ex emb) - up to 6.8 Watts 27, 57, 67 & 77 (Ex d) - up to 10.0 Watts 77 (Ex d) - (90L) 9.0W magnetically latched lower coil (I15U) 11.5W magnetically de-latched upper coil 77 (Ex d) - (10LP)* 1.0W holding power 3.5W energise and (28LP)* 2.8W holding power 8.0W energise (Only available with selected models)				
Protection Class (Ex ia) - 28, 38, 58, 68 & 78 Series	28 - II 2 GD Ex ia IIC Gb T6 (Tamb = -60°C to +60°C) II 2 GD Ex ia IIC Gb T4 (Tamb = -60°C to +95°C) 38 - II 1 G Ex ia IIC Ga T6 (-60°C ≤ Ta ≤ +60°C) 58 - II 1 GD Ex ia IIC Ga T6 (Tamb = -60°C to +60°C) 68 - II 1 GD Ex ia IIC Ga T6 (Tamb = -60°C to +60°C) 78 - II 1 GD Ex ia IIC Ga T6 (Tamb = -60°C to +60°C) II 1 GD Ex ia IIC Ga T4 (Tamb = -60°C to +95°C)				
Resistance (Ω) and (Ex ia) - Safety Parameters	<table border="0" style="width: 100%;"> <tr> <td style="width: 50%; vertical-align: top;">               28 &amp; 78 - (Ex ia) - 155 Ohms  <b>Safety Parameters: 28 &amp; 78 Series</b>                 Ui = 31 Vdc, li = 210 mA, Pi = 1.5 W, Ci ≈ 0 μF, Li ≈ 0 mH                Coil Resistance : 155 Ohm ± 5%                Minimum Current Required @ solenoid coil = 80 mA             </td> <td style="width: 50%; vertical-align: top;">               28 &amp; 78 (Ex ia) - 370 Ohms  <b>Safety Parameters: 28 &amp; 78 Series</b>                 Ui = 31 Vdc, li = 210 mA, Pi = 1.5 W, Ci ≈ 0 μF, Li ≈ 0mH                Coil Resistance : 370 Ohm ± 5%                Minimum Current Required @ solenoid coil = 32 mA             </td> </tr> <tr> <td style="vertical-align: top;">               38, 58 &amp; 68 - (Ex ia) - 135 Ohms  <b>Safety Parameters: 38, 58 &amp; 68 Series</b>                 Ui = 35 Vdc, li = 600mA, Pi = 3 W, Ci ≈ 0 μF, Li ≈ 0 mH                Coil Resistance : 135 Ohm ± 5%                Minimum Current Required @ solenoid coil = 80 mA             </td> <td></td> </tr> </table>	28 & 78 - (Ex ia) - 155 Ohms <b>Safety Parameters: 28 &amp; 78 Series</b>  Ui = 31 Vdc, li = 210 mA, Pi = 1.5 W, Ci ≈ 0 μF, Li ≈ 0 mH Coil Resistance : 155 Ohm ± 5% Minimum Current Required @ solenoid coil = 80 mA	28 & 78 (Ex ia) - 370 Ohms <b>Safety Parameters: 28 &amp; 78 Series</b>  Ui = 31 Vdc, li = 210 mA, Pi = 1.5 W, Ci ≈ 0 μF, Li ≈ 0mH Coil Resistance : 370 Ohm ± 5% Minimum Current Required @ solenoid coil = 32 mA	38, 58 & 68 - (Ex ia) - 135 Ohms <b>Safety Parameters: 38, 58 &amp; 68 Series</b>  Ui = 35 Vdc, li = 600mA, Pi = 3 W, Ci ≈ 0 μF, Li ≈ 0 mH Coil Resistance : 135 Ohm ± 5% Minimum Current Required @ solenoid coil = 80 mA	
28 & 78 - (Ex ia) - 155 Ohms <b>Safety Parameters: 28 &amp; 78 Series</b>  Ui = 31 Vdc, li = 210 mA, Pi = 1.5 W, Ci ≈ 0 μF, Li ≈ 0 mH Coil Resistance : 155 Ohm ± 5% Minimum Current Required @ solenoid coil = 80 mA	28 & 78 (Ex ia) - 370 Ohms <b>Safety Parameters: 28 &amp; 78 Series</b>  Ui = 31 Vdc, li = 210 mA, Pi = 1.5 W, Ci ≈ 0 μF, Li ≈ 0mH Coil Resistance : 370 Ohm ± 5% Minimum Current Required @ solenoid coil = 32 mA				
38, 58 & 68 - (Ex ia) - 135 Ohms <b>Safety Parameters: 38, 58 &amp; 68 Series</b>  Ui = 35 Vdc, li = 600mA, Pi = 3 W, Ci ≈ 0 μF, Li ≈ 0 mH Coil Resistance : 135 Ohm ± 5% Minimum Current Required @ solenoid coil = 80 mA					
Terminal Block (FP Operator)	The type MK3 terminal block can accommodate solid conductors between the range of 0.5mm <sup>2</sup> to 2.5mm <sup>2</sup> and flexible conductors between the range of 0.5mm <sup>2</sup> to 1.5mm <sup>2</sup>				
Repair Kit	For solenoid operator specific RK (Repair Kits), please contact Bifold sales department				
Seal Repair Kit	For solenoid operator specific SK (Seal Kits), please contact Bifold sales department				
Coil Repair Kit	For solenoid operator specific CRK (Coil Repair Kits), please contact Bifold sales department				

\* Low power

## Direct Acting & Indirect Acting Schematics

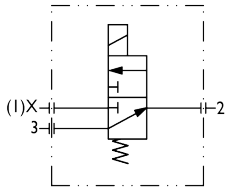
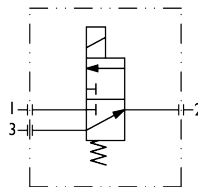
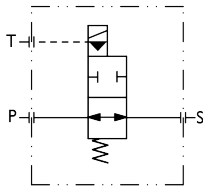
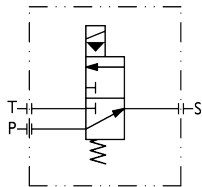
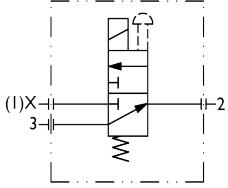
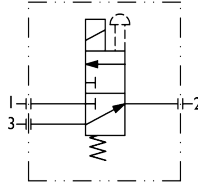
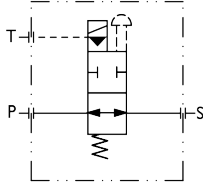
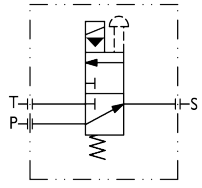
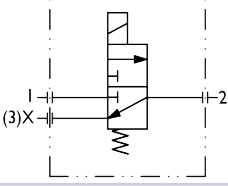
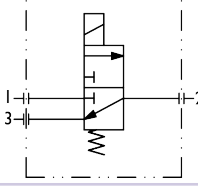
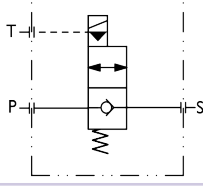
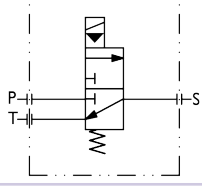
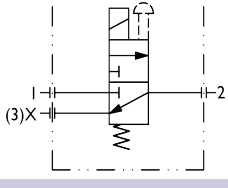
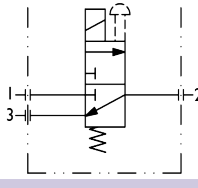
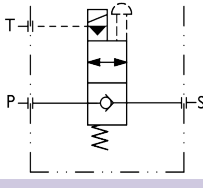
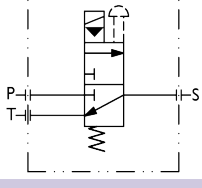
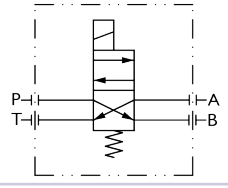
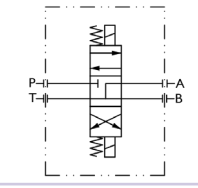
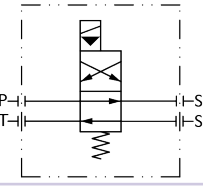
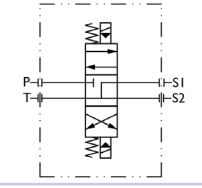
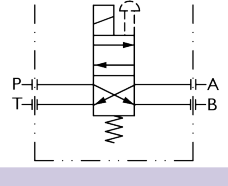
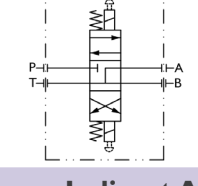
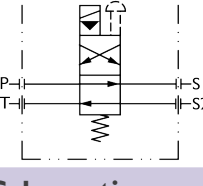
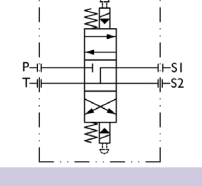
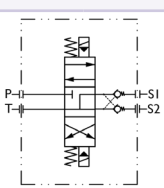
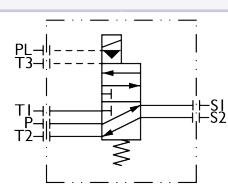
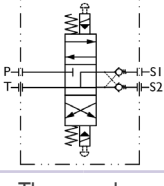
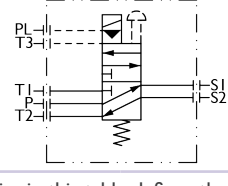
Configuration	Direct Acting Schematics		Indirect Acting Schematics	
	2/2	3/2	2/2	3/2
Auto Reset NO (Normally Open)				
Manual NO (Normally Open)				
Auto Reset NC (Normally Closed)				
Manual NC (Normally Closed)				
Configuration	Direct Acting Schematics		Indirect Acting Schematics	
	4/2	4/3	4/2	4/3
Auto Reset				
Manual				
Configuration	Indirect Acting Schematics			
	4/3 BC		5/2	
Auto Reset				
Manual				

The manual operator feature attached to the valve schematics in this table defines the push button / spring return manual override option, other manual options are also available - please contact Bifold

# 08 Solenoid Valves Hydraulic

## Standard & Slimline Wiring Diagrams

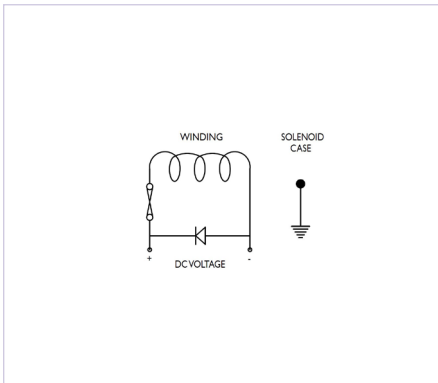

■ (Ex emb) - 24 & 74AT4 Series

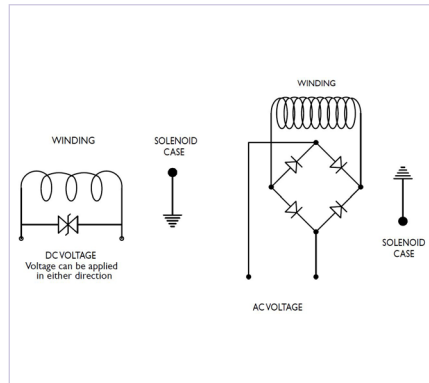

■ (Ex d) - 27, 57, 67 & 77 Series

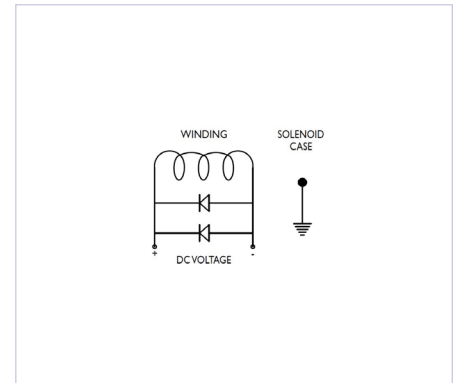

■ (Ex ia) - 28, 38, 58, 68 & 78 Series



# 08 Solenoid Valves Hydraulic

## Product Configurator

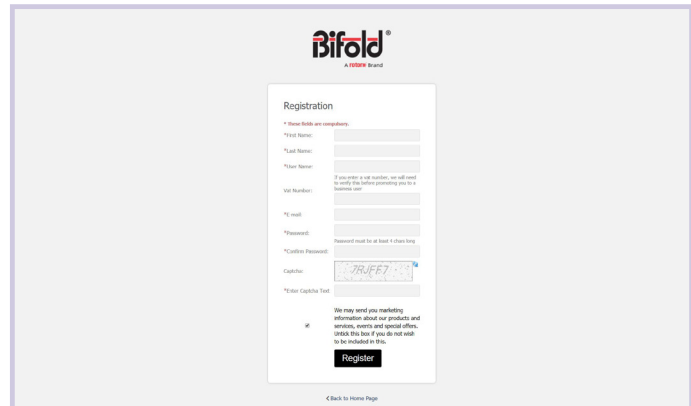
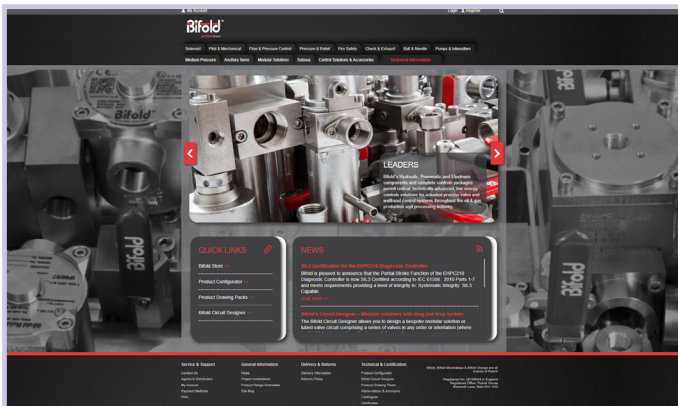

1. Visit [www.bifold.co.uk/Index.aspx](http://www.bifold.co.uk/Index.aspx) and go to the technical information tab or the technical & certification section of the footer and click the product configurator link.
2. Register or login to enter the product configurator.

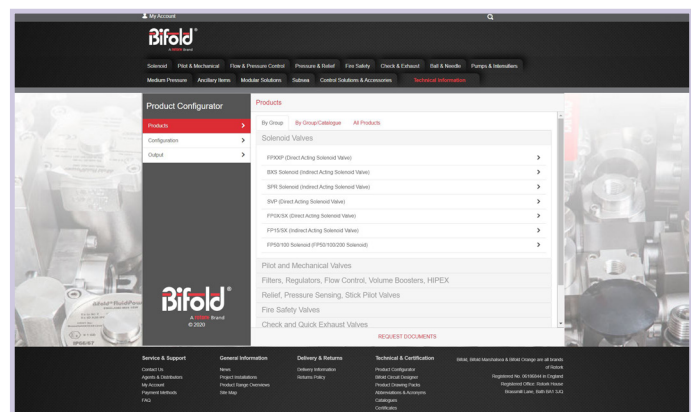
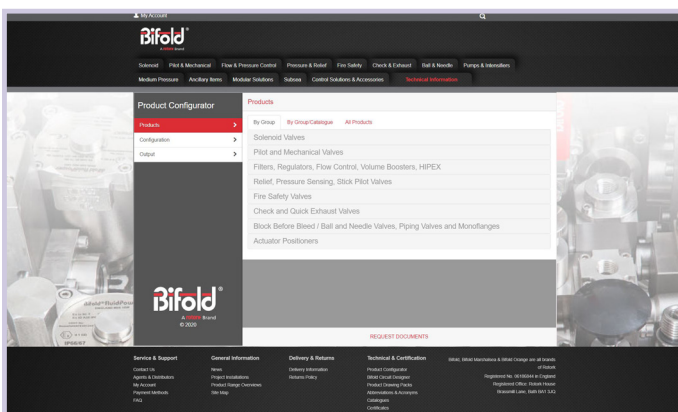

3. Simply choose and click the product range you would like from the products list.
4. Choose and click the model code you would like to configure from the products list.

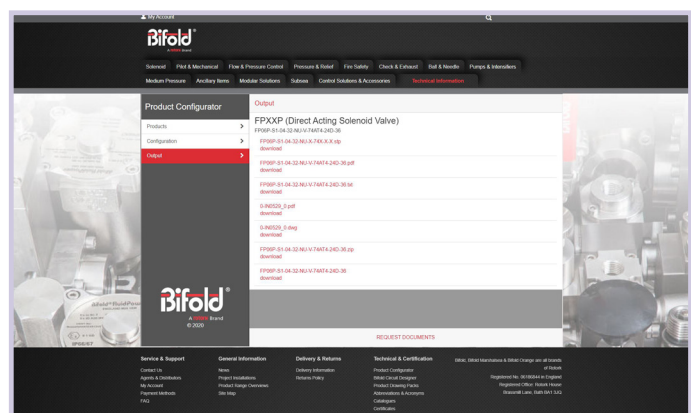
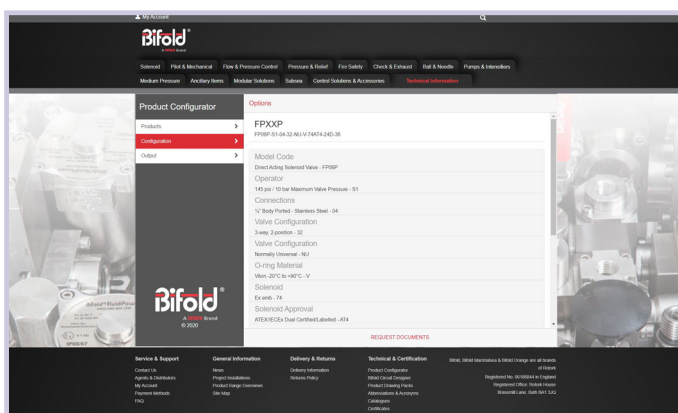

5. Configure the selected product to your required specification.
6. Once you have configured the products to your exact specifications, simply click 'request documents' which will automatically create a bespoke datasheet, 2D dimensional drawing and 3D CAD / Step file in real time, ready to download.

---

## Notes

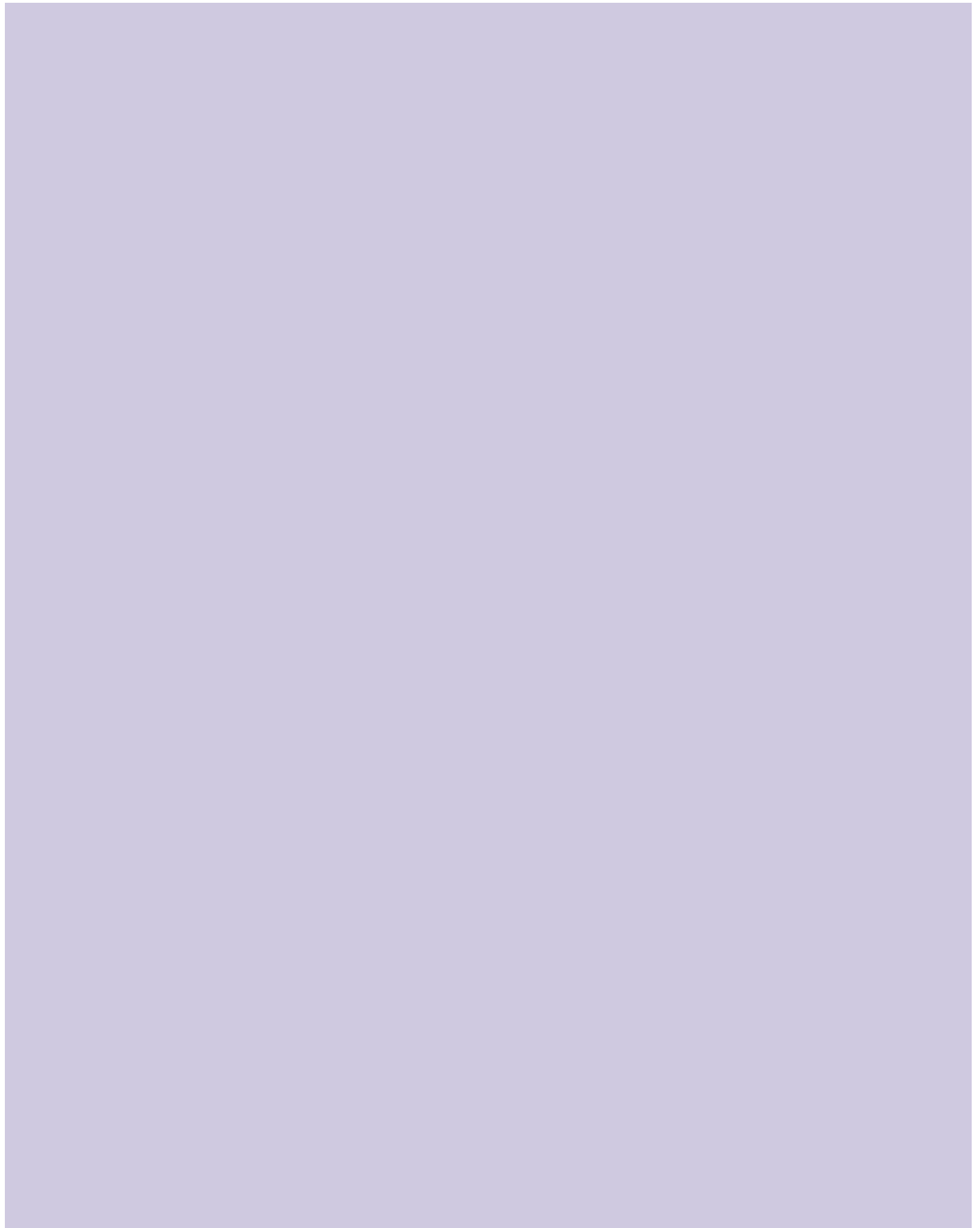

# 08

## Solenoid Valves Hydraulic

### Notes

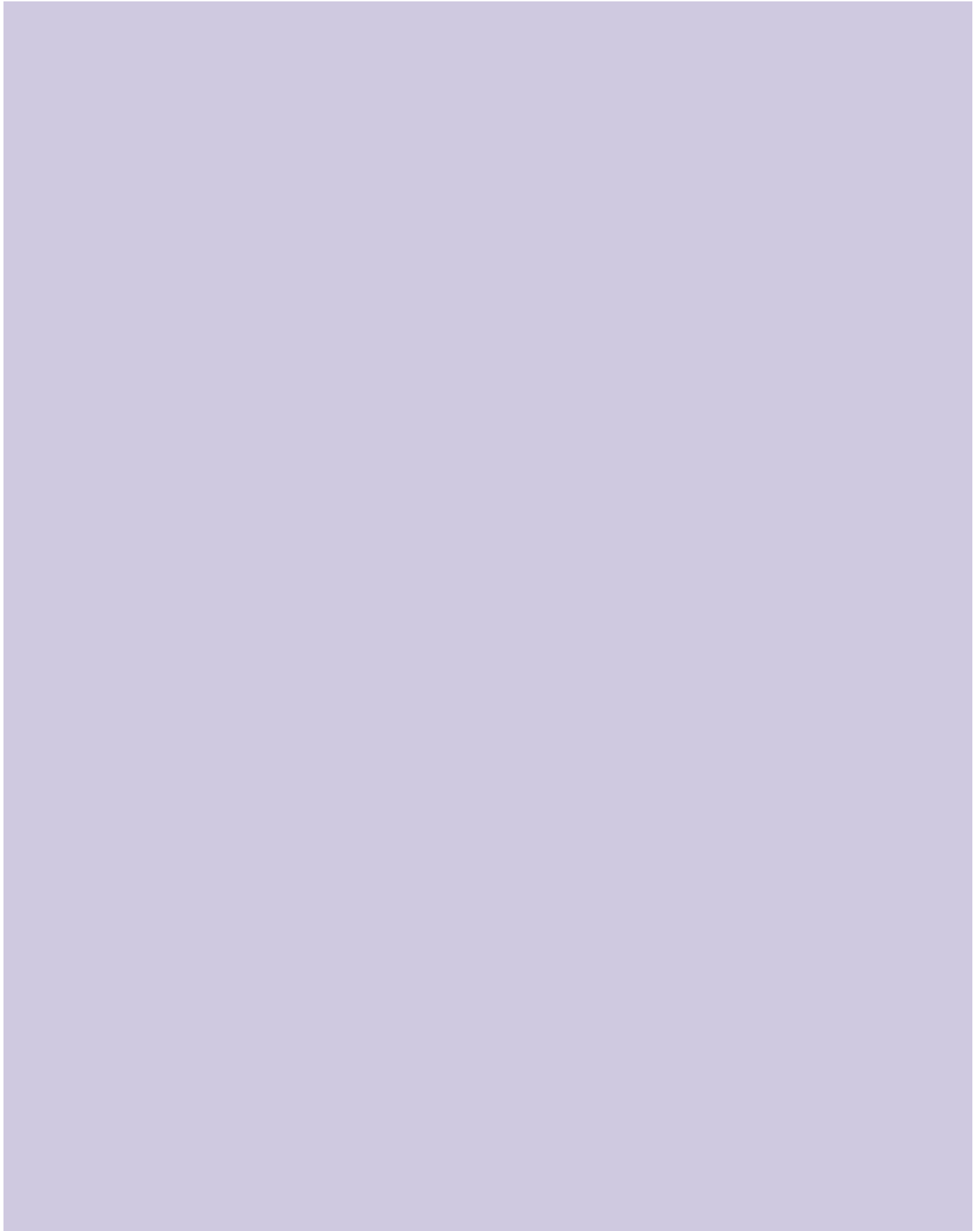

---

## Notes

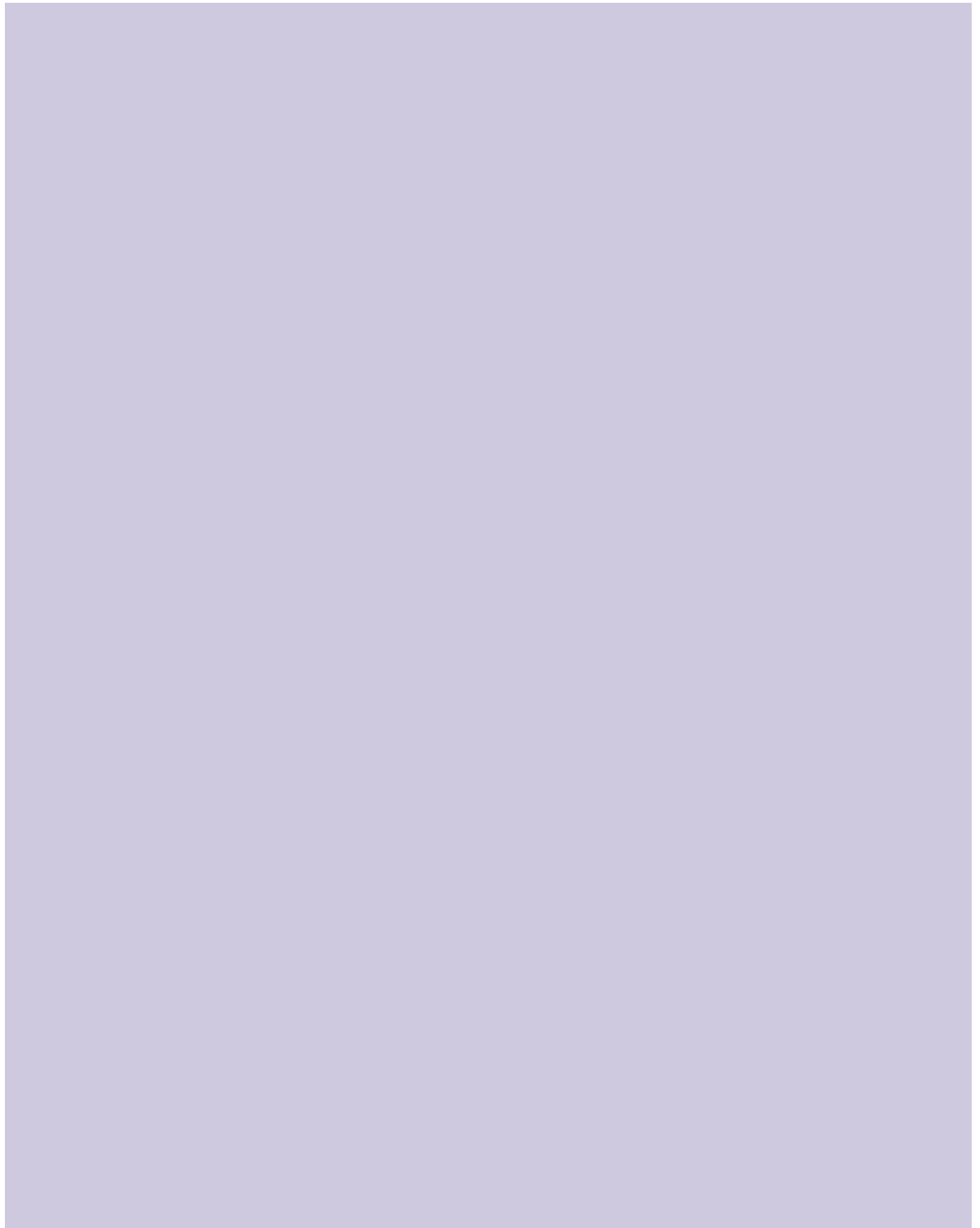

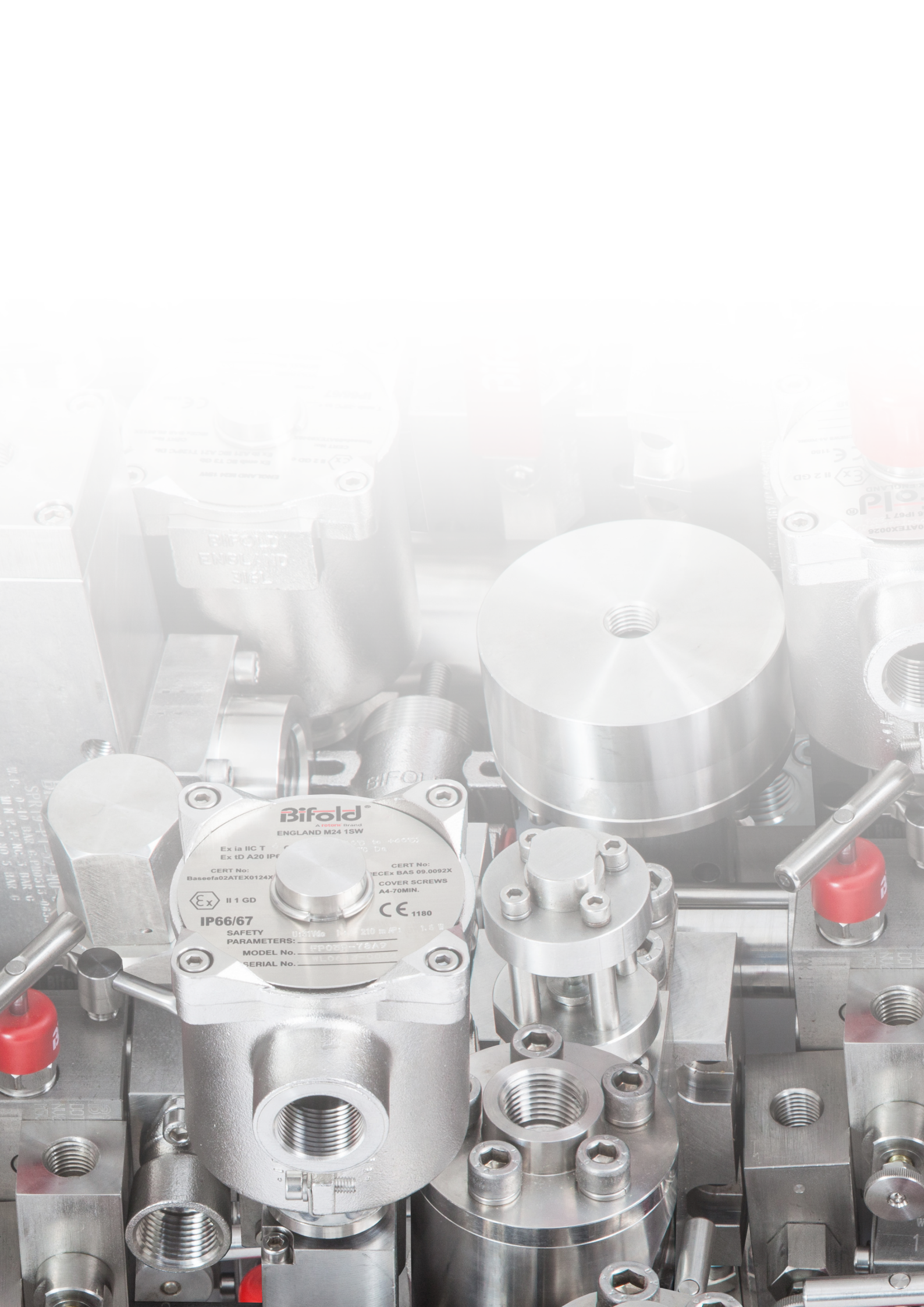

**Bifold**  
A 10000 Brand  
ENGLAND M24 15W

Ex ia IIC T  
Ex tD A20 IP66/67

CERT No: Baseefa02ATEX0124X

II 1 GD

IP66/67

SAFETY PARAMETERS:

MODEL No. FP000-76A7

SERIAL No. 1180

CERT No: CECEx BAS 09.0092X

COVER SCREWS A4-70MIN.

CE 1180



**Bifold**  
A FORTRESS Brand  
ENGLAND M24 1SW

Ex ia IIC T  
Ex tD A20 IP66

CERT No: Baseofa02ATEX0124X

Ex II 1 GD

IP66/67

SAFETY

PARAMETERS:

MODEL No. EP000-756A9

SERIAL No. 10000000000000000000

CERT No: ECEX BAS 09-0092X

COVER SCREWS

A4-70MIN.

CE 1180

1-32-NC-00-78AG-570  
FM0613-0060  
P. 2 - 10 BAR



# EFFICIENCY THROUGH TECHNOLOGY



#### Accuracy of information

We take care to ensure that product information in this catalogue is reasonably accurate and up-to-date. However, our products are continually developed and updated so to ensure accurate and up-to-date information please refer to the product catalogue issue list on our web site or contact a member of our sales team.

When selecting a product, the applicable operating system design must be considered to ensure safe use. The products function, material compatibility, adequate ratings, correct installation, operation and maintenance are the responsibilities of the system designer and user.

#### Quality Assurance

All Bifold products are manufactured to a stringent QA programme to ensure that every product will give optimum performance and reliability. We are third party certified to BS EN ISO 9001. We reserve the right to make changes to the specifications and design etc., without prior notice.

Registered No. 06186844 in England.

Registered Office: Rotork House,  
Brassmill Lane, Bath, BA1 3JQ.

**Bifold**  
Broadgate, Oldham Broadway Business  
Park, Chadderton, Greater Manchester,  
OL9 9XA, UK.

Tel: +44 (0) 161 345 4777  
Email: [bifold.sales@rotork.com](mailto:bifold.sales@rotork.com)

**USA Office**  
Tel: +1 (713) 304 4012

**Singapore Office**  
Mobile: +65 9824 5580

Email: [bifold.sales@rotork.com](mailto:bifold.sales@rotork.com)

Bifold, Bifold Marshalsea, & Bifold  
Orange are all brands of Rotork

**rotork**<sup>®</sup>

[bifold.co.uk](http://bifold.co.uk)

PUB171-004-00  
Issue 03/20

© 2020 Bifold